



# AK7401

## Rotary Position Sensor IC

### 1. General Description

The AK7401 is a monolithic Hall-Effect sensor IC that specializes in detecting rotation angle. A contactless rotary position sensor is easily designed with a magnet.

The AK7401 is only sensitive to the magnetic flux density applied parallel to the IC surface. This is obtained through a magnetic concentrator which is mounted on the Hall-Effect elements. It is advantageous to accurate angular measurements against mechanical displacement.

To detect the rotation angle of a magnet, the AK7401 provides a 12-bit angle data. The angle data output is available via PWM and serial data protocols.

### 2. Applications

Steering wheel position sensor, Pedal position sensor, Throttle position sensor, EGR valve position sensor, Turbo valve position sensor, Motor shaft position sensor

### 3. Features

- 360° Contactless Angle Sensor
- Angle Resolution : 12bit
- Angle Linearity Error:  $\pm 0.95^\circ @ 25^\circ\text{C}$
- Over Voltage Protection: +16V @VDD pin
- Reverse Voltage Protection: -16V @VDD, VSS pin
- Automotive Temperature Range:  $-40^\circ\text{C}$  to  $+150^\circ\text{C}$
- AEC-Q100 Compliant
- Output Interface: 3-wire SPI / PWM Push-Pull / PWM NMOS Open-Drain
- User Programmable
  - Zero degree point
  - Magnet rotation direction: CCW or CW
  - Angle data average: OFF, SPC (2 times average), HP (8 times average)
  - PWM frequency: 250, 500 and 1000Hz
  - PWM polarity
  - OUT pin output type: Push-Pull / NMOS Open-Drain
- Self-diagnostic Functions
  - Mismatch detect function for triple-redundant EEPROM data
  - Under and over supply voltage detect function
  - Under and over magnetic flux density detect function
- Environmental Friendly (RoHS Compliant)
  - Lead free
  - Halogen free

**4. Table of Contents**

1.	General Description.....	1
2.	Applications .....	1
3.	Features.....	1
4.	Table of Contents .....	2
5.	Functional Block Diagram .....	3
6.	Pin Configuration .....	4
7.	Absolute Maximum Ratings.....	4
8.	EEPROM Characteristics .....	5
9.	Operating Conditions.....	5
10.	Electrical and Magnetic Characteristics .....	5
11.	Serial I/F Digital Characteristics .....	6
12.	PWM Characteristics.....	7
13.	Supply Voltage Level Detection Characteristics .....	8
14.	Programmable Mode Descriptions.....	9
15.	Serial I/F Protocol .....	11
16.	Self-diagnostic Function .....	13
17.	Register & EEPROM Address Map &Description .....	15
18.	Default Settings Information .....	25
19.	Recommended External Circuit .....	26
20.	Package Information .....	27
	■ Outline Dimensions .....	27
	■ Materials.....	27
	■ Marking.....	28
	■ Sensitive Area Location .....	28
21.	Revision History.....	28

**5. Functional Block Diagram**

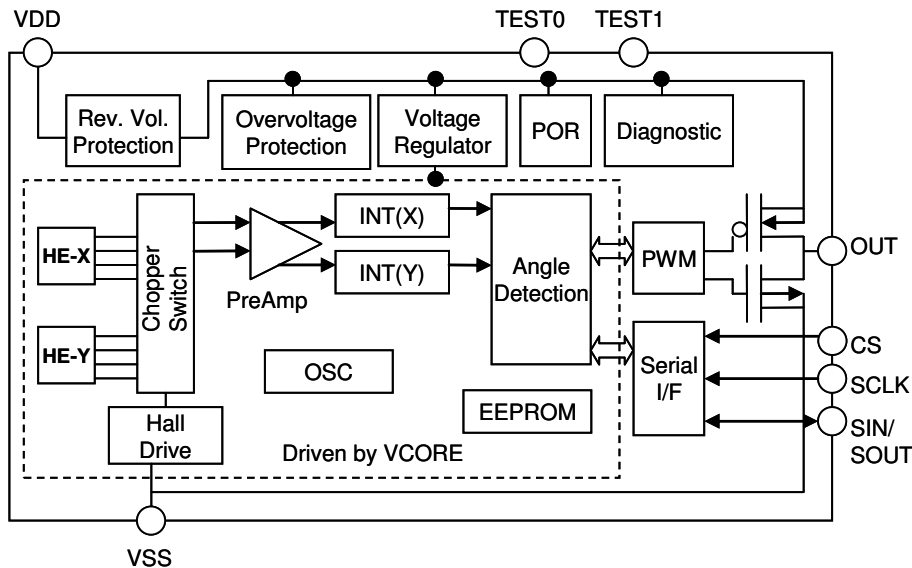

Figure 1. Functional Block Diagram

Table 1. Functional Block Description

Block name	Function
HE-X / HE-Y	Detect the X/Y-compositions of the magnetic flux density applied parallel to the IC package surface by a magnetic concentrator.
Chopper Switch	Switch the current direction in order to cancel the Hall elements offset.
PreAmp	Amplify the signals from the Hall elements.
Hall Drive	Drive the constant current for the Hall elements.
OSC	Generate master clock.
INT-X / Y	Integrate the amplified signals to reduce the noise.
Angle Detection	Calculate the 12-bit angle data from the X/Y integrated signal.
PWM	Generate the PWM signal based on the 12-bit angle data.
Serial I/F	Interface based on 3-wire serial protocol.
Rev. Vol. Protection	Protect the IC from the reverse connection to the power supply pin.
Overvoltage Protection	Protect the IC from an over voltage supply.
Voltage Regulator	Regulate the internal bias voltage.
POR	Generate a reset signal at the time of low supply voltage.
EEPROM	Non-volatile memory. The stored data is triply copied to the other particular address automatically.
Diagnostic	Detect the level of supply voltage, the level of the magnetic flux density and a mismatch of the triple-redundant configuration EEPROM data.

## 6. Pin Configuration

Table 2. Pin Description

No.	Symbol	I/O	Type	Function
1	VDD	-	Power	Power Supply Pin
2	TEST0	-	-	Test Dedicated Pin (Note 1)
3	CS	I	Digital	Chip Select Signal Pin
4	SCLK	I	Digital	Serial Clock Signal Pin
5	OUT	O	Digital	PWM Output Pin
6	TEST1	-	-	Test Dedicated Pin (Note 1)
7	SIN/SOUT	I/O	Digital	Serial Input/Output Data Signal Pin
8	VSS	-	Power	Ground Pin

Note 1. The TEST0 and TEST1 pins must be open.

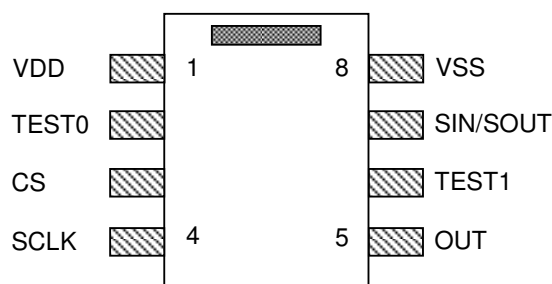

Figure 2. Pin Configuration

## 7. Absolute Maximum Ratings

Parameter	Symbol	Min.	Max.	Unit	Notes
Supply Voltage	$V_{DD}$	-16	16 (Note 2)	V	VDD, VSS pin over voltage protection reverse voltage protection
Terminal Voltage 1	$V_{TERM1}$	-0.3	$V_{DD}$ (Note 2)	V	OUT, SIN/SOUT, CS, SCLK pin $V_{DD} > V_{TERM1}$
Terminal Voltage 2	$V_{TERM2}$	-0.3	6	V	TEST0, TEST1 pin $V_{DD} > V_{TERM2}$
Output Current on OUT pin	$I_{OUT1}$	-10	10	mA	
Output Current on SIN/SOUT pin	$I_{OUT2}$	-1.25	1.25	mA	
Storage Temperature	Tstg	-50	+150	°C	

Note 2. The values of  $V_{DD}$  and  $V_{TERM1}$  are for instantaneous voltage by accident, are not for a constant condition such as an operating condition.

WARNING: Operation at or beyond these limits may cause permanent damage to the device. Normal operation is not guaranteed at these extremes.

### 8. EEPROM Characteristics

(V<sub>DD</sub>=4.0 to 5.5V)

Parameter	Symbol	Min.	Typ.	Max.	Unit	Notes
EEPROM Endurance	Een			1000	Cycle	This parameter is guaranteed by design.
Ambient Temperature in Writing	Taw	0		+85	°C	
Writing Time	Tw			20	ms	

### 9. Operating Conditions

Parameter	Symbol	Min.	Typ.	Max.	Unit	Notes
Supply Voltage	V <sub>DD</sub>	4.0	5.0	5.5	V	
Operating Ambient Temperature	Ta	-40	-	+150	°C	

WARNING: Electrical and magnetic characteristics are not guaranteed when operated at or beyond these conditions.

### 10. Electrical and Magnetic Characteristics

(Ta=-40 to +150°C, V<sub>DD</sub>=4.0 to 5.5V; unless otherwise specified)

Parameter	Symbol	Conditions	Min.	Typ.	Max.	Unit
Magnetic Flux Density Range	B <sub>RANGE</sub>		20	50	70	mT
Angle Detection Range	A <sub>RANGE</sub>		0		359.9	Deg.
Angle Resolution	A <sub>RES</sub>	12bit		0.088		Deg.
Angle Linearity Error	A <sub>INL</sub>	Ta=25°C SPC,HP settings	-0.95		+0.95	Deg.
Thermal Angle Drift Caused by Sensitivity Mismatch	H <sub>MX</sub>	Ta=25°C basis SPC,HP settings	-0.45		+0.45	Deg.
Thermal Angle Drift Caused by ADC offset	ADC <sub>OS</sub>		-0.18		+0.18	Deg.
Angle Output Noise	A <sub>NOISE</sub>	1σ SPC settings			+0.2	Deg.
Angle Update Period	A <sub>CYCLE</sub>			100	110	μs
Supply Current	I <sub>DD</sub>	No output load		8	12	mA
Startup Time (Note 3)	T <sub>START</sub>				2.0	ms

Note 3. Startup time is defined as the time from when V<sub>DD</sub> reaches operating voltage level to when the serial data connection is available.

**11. Serial I/F Digital Characteristics**

**1) DC Characteristics**

(Ta=-40 to +150°C, V<sub>DD</sub>=4.0 to 5.5V; unless otherwise specified)

Parameter	Symbol	Conditions	Min.	Typ.	Max.	Unit
Input High Level	V <sub>HSI</sub>		0.7V <sub>DD</sub>			V
Input Low Level	V <sub>LSI</sub>				0.3V <sub>DD</sub>	V
Input Current	I <sub>SI</sub>		-10		+10	μA
Output High Level	V <sub>HSO</sub>	I <sub>OUT2</sub> =+400uA	0.8V <sub>DD</sub>			V
Output Low Level	V <sub>LSO</sub>	I <sub>OUT2</sub> =-700uA	-0.3		0.2V <sub>DD</sub>	V

**2) AC Characteristics**

(Ta=-40 to +150°C, V<sub>DD</sub>=4.0 to 5.5V; unless otherwise specified)

Parameter	Symbol	Conditions	Min.	Typ.	Max.	Unit
SCLK High Time	T <sub>H</sub>		200			ns
SCLK Low Time	T <sub>L</sub>		200			ns
SCLK Rise Time (Note 4)	T <sub>r</sub>				30	ns
SCLK Fall Time (Note 4)	T <sub>f</sub>				30	ns
CS Setup Time	T <sub>CSS</sub>		100			ns
CS Hold Time	T <sub>CSH</sub>		200			ns
Data Setup Time	T <sub>DS</sub>		100			ns
Data Hold Time	T <sub>DH</sub>		100			ns
Data Valid Time	T <sub>DV</sub>	C <sub>load</sub> =100pF, no load current			200	ns
Wait Time	T <sub>EW</sub>	EEPROM write time	20			ms
Wait Time	T <sub>RW</sub>	Register write time	2.5			μs

Note 4. This parameter is guaranteed by design.

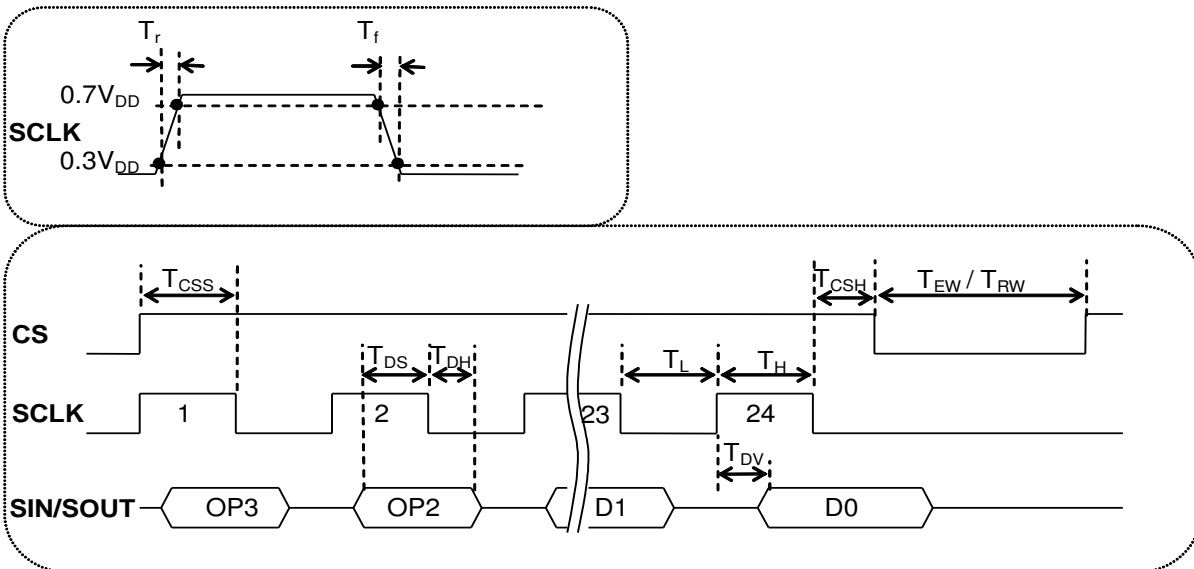

Figure 3. Serial I/F AC Characteristics

**12. PWM Characteristics**

**1) DC Characteristics**

(Ta=-40 to +150°C, V<sub>DD</sub>=4.0 to 5.5V; unless otherwise specified)

Parameter	Symbol	Conditions	Min.	Typ.	Max.	Unit
Output Low Level	V <sub>HP</sub>	I <sub>OUT</sub> =-4mA		5	10	%V <sub>DD</sub>
Output High Level	V <sub>LP</sub>	I <sub>OUT</sub> =4mA	90	95		%V <sub>DD</sub>
PWM Output Resolution	R <sub>PWM</sub>			0.0195		% <sub>DC</sub> /LSB

**2) AC Characteristics**

(Ta=-40 to +150°C, V<sub>DD</sub>=4.0 to 5.5V; unless otherwise specified)

Parameter	Symbol	Conditions	Min.	Typ.	Max.	Unit
PWM Frequency	F <sub>PWM</sub>	E_PWMF=0x3F	225	250	275	Hz
		E_PWMF=0x07	450	500	550	Hz
		E_PWMF=0x00	900	1000	1100	Hz
Rise Time	T <sub>rOUT</sub>	Push-Pull output 2.2nF, 10kΩ	0.1	0.22	0.6	μs
Fall Time	T <sub>fOUT</sub>	Push-Pull output Open drain output 2.2nF, 10kΩ	0.2	0.47	0.9	μs
Rise Time	T <sub>rOUT</sub>	Open drain output 2.2nF, 10kΩ	40	50	60	μs
PWM Jitter	J <sub>PWM</sub>	1σ			0.05	% <sub>DC</sub>
Duty at 0°		PWM polarity positive	9.9	10	10.1	% <sub>DC</sub>
Duty at 359.9°		PWM polarity positive	89.9	90	90.1	% <sub>DC</sub>
Duty at 0°		PWM polarity negative	89.9	90	90.1	% <sub>DC</sub>
Duty at 359.9°		PWM polarity negative	9.9	10	10.1	% <sub>DC</sub>

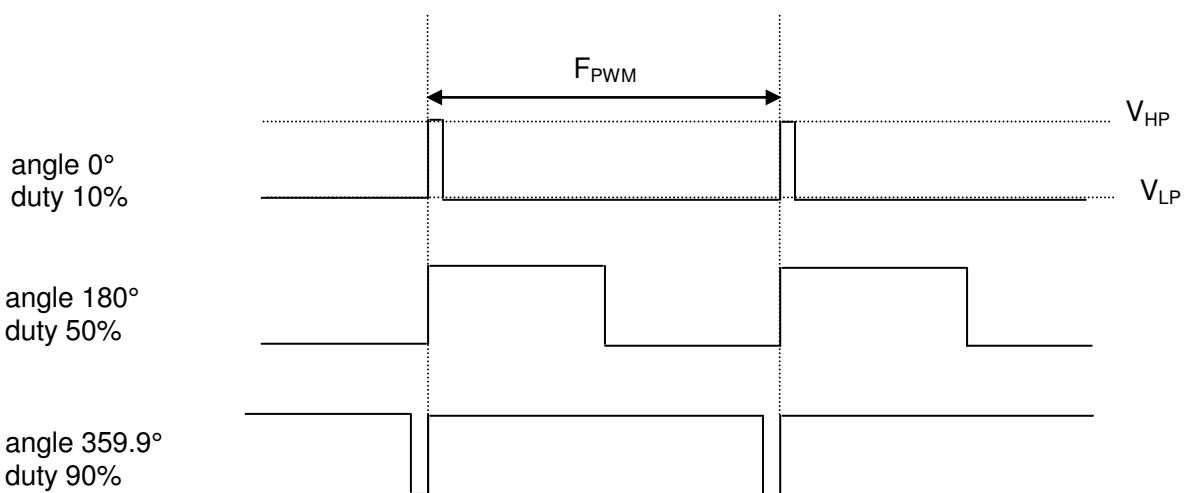

Figure 4. Duty at Each Angle Position (PWM polarity positive case)

**13. Supply Voltage Level Detection Characteristics**

**1) DC Characteristics**

(Ta=-40 to +150°C, unless otherwise specified)

Parameter	Symbol	Conditions	Min.	Typ.	Max.	Unit
Power-on Reset Release Level	V <sub>1</sub>		2.75	3.4	3.85	V
Under Voltage Detection Release Level	V <sub>2</sub>		3.45	3.7	3.95	V
Over Voltage Detection Level	V <sub>3</sub>		5.8	6.0	6.4	V
Output Shutdown Level	V <sub>4</sub>		6.9	7.3	7.6	V
Output Recovery Level	V <sub>5</sub>		6.15	6.5	6.85	V
Over Voltage Detection Release Level	V <sub>6</sub>		5.55	5.8	6.15	V
Under Voltage Detection Level	V <sub>7</sub>		3.3	3.5	3.8	V
Power-on Reset Level	V <sub>8</sub>		2.3	2.9	3.4	V

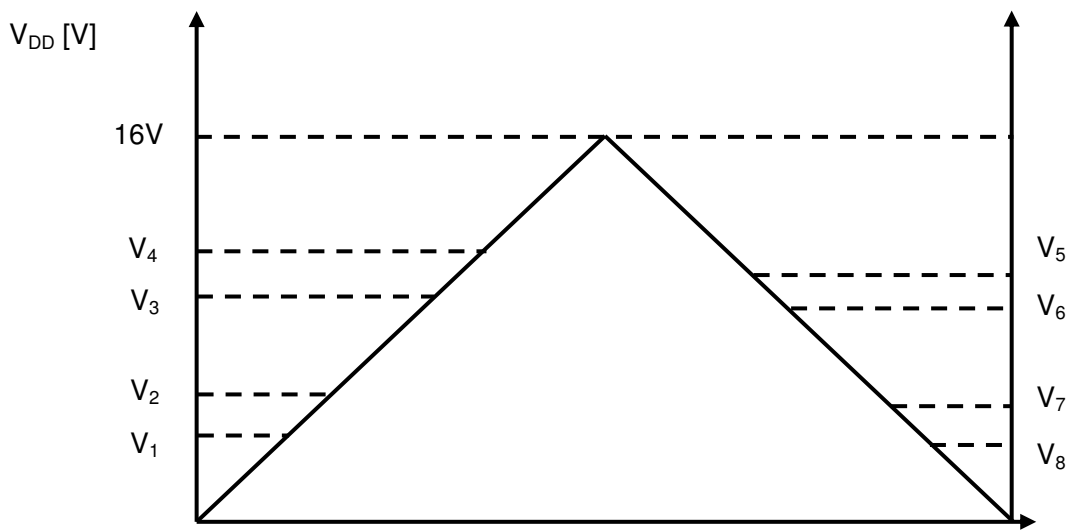

Figure 5. Supply Voltage Level Detection Diagram



**14. Programmable Mode Descriptions**

The AK7401 has the two operating modes (Normal Mode and User Mode). In User Mode, it is able to read and write the internal registers and EEPROM according to a serial I/F. User Mode supports the end-user programming such as zero point adjustment, magnet rotation direction, angle data averaging, PWM frequency, PWM polarity and PWM output type.

When the power supply is turned ON, the AK7401 automatically resets the internal register and loads the EEPROM configuration data to set the internal configuration register. After startup sequence, the AK7401 operates in Normal Mode.

• **Mode Description**

Each mode can be changed by writing a specific OPCODE and DATA on a specific address as the diagram below.

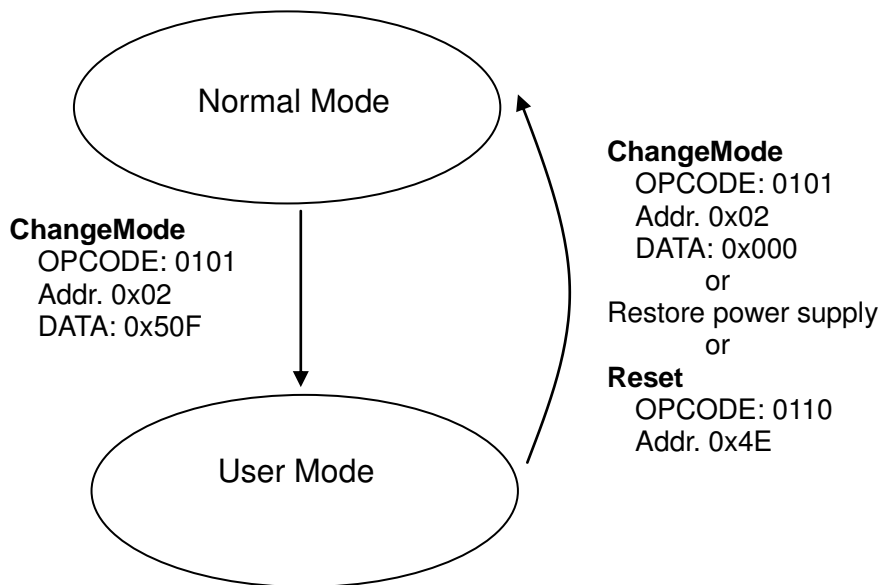

Figure 6. Operation Mode Transition Diagram

Table 3. Operation Mode Description

Mode Name	Note
<b>Normal Mode</b>	In Normal Mode, it is not able to access the internal register and EEPROM except register R_ANG (Addr.0x00) and register R_CHMD (Addr.0x02). Available operation codes are ReadAngle and ChangeMode. The transmission time interval of ReadAngle operation code needs to be equal to angle data update period or longer. If the interval time is shorter, R_ANG register is not updated to the latest processing data. In case of changing operation mode from User Mode to Normal Mode, all registers are automatically initialized and loads the EEPROM configuration data to set the internal configuration register.

<b>User Mode</b>	<p>In User Mode, it is able to access the internal configuration register and EEPROM. To set the following parameters in Normal Mode, configuration data need to be stored in EEPROM.</p> <ol style="list-style-type: none"> <li>1. Zero Degree Point Configuration of the zero degree point defines the origin of the output angle data. It is programmable at any angle position.</li> <li>2. Magnet Rotation Direction Configuration of the magnet rotation direction defines the increase or decrease of the output angle data relative to the magnet rotation direction. When it is selected to CCW, the output angle data increases in response to counter-clockwise direction magnet rotation.</li> <li>3. Angle Data Averaging Configuration of angle data averaging provides OFF, SPC and HP settings. In OFF setting, the AK7401 calculates the angle data without averaging procedure. In SPC setting, the AK7401 calculates the angle data by 2 times averaging. In HP setting, the AK7401 calculates the angle data by 8 times averaging.</li> <li>4. PWM Frequency Configuration of PWM frequency provides 250, 500 and 1000Hz settings.</li> <li>5. PWM Polarity Configuration of PWM polarity provides plus and minus polarity settings. In plus polarity settings, the highest angle data corresponds to maximum PWM duty.</li> <li>6. OUT Pin Output Type Configuration of the OUT pin output type provides Push-Pull and NMOS Open-Drain.</li> <li>7. Magnetic Flux Density Detection Range Configuration of magnetic flux density detection range provides under limit setting and upper limit setting.</li> <li>8. Self-diagnostic Configuration Configuration of self-diagnosis defines the activation or inactivation of each self- diagnostic functions.</li> <li>9. Memory Lock In order to prevent rewriting EEPROM incorrectly, it is able to lock the memory. Once the configuration of memory lock is enabled, it is not possible to change EEPROM anymore.</li> </ol> <p>In User Mode, the OUT pin goes to high-impedance (Hi-Z) output. Electrical and magnetic characteristics are not guaranteed in User Mode.</p>
------------------	---

**15. Serial I/F Protocol**

Figure 7 shows timing chart on serial interface protocol. Data communication is only available when the CS pin set to “H”. To write the internal register or EEPROM, serial data must be input via the SIN/SOUT pin on the falling edge of SCLK. To read the internal register or EEPROM, the AK7401 outputs serial data on the rising edge of SCLK.

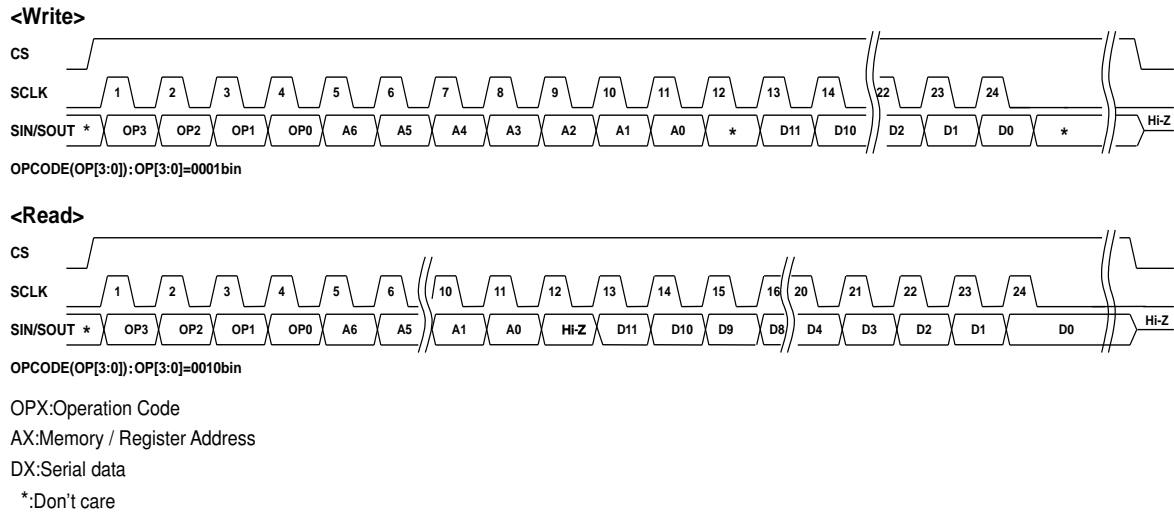

Figure 7. Serial I/F Timing Chart

● **OPCODE**

Table 4. Operation Code Description

OPCODE [3:0]	Code name	Description	Accessibility	
			Normal Mode	User Mode
0000	N/A	N/A	invalid	invalid
0001	WriteEEPROM	Stores data to EEPROM	invalid	valid
0010	ReadEEPROM	Reads data from EEPROM	invalid	valid
0011	WriteReg	Stores data to the internal register	invalid	valid
0100	ReadReg	Reads the internal register data	invalid	valid
0101	ChangeMode	Changes operating mode	valid	valid
0110	Reset	Restarts the AK7401	invalid	valid
0111	N/A	N/A	invalid	invalid
1000	N/A	N/A	invalid	invalid
1001	ReadAngle	Reads the angle data	valid	valid
1010	N/A	N/A	invalid	invalid
1011	N/A	N/A	invalid	invalid
1100	N/A	N/A	invalid	invalid
1101	N/A	N/A	invalid	invalid
1110	N/A	N/A	invalid	invalid
1111	N/A	N/A	invalid	invalid

- Data sequence

## 1) Store Data

23	22	21	20	19	18	17	16	15	14	13	12	11	10	9	8	7	6	5	4	3	2	1	0
OP[3:0]				ADDR[6:0]								*	DATA[11:0]										

OP[3:0]: "0001" (to EEPROM), "0011"(to Register)

ADDR[6:0]: Register or EEPROM address number(See Address map)

DATA[11:0]: 12-bit data to store

(\*: Don't care)

The configuration of EEPROM data has triple redundancy. When a data is written to a specific EEPROM address (0x03 to 0x0B, 0x0D) via WriteEEPROM operation code, the stored data is triply copied to other particular address automatically.

## 2) Read Data

23	22	21	20	19	18	17	16	15	14	13	12	11	10	9	8	7	6	5	4	3	2	1	0
OP[3:0]				ADDR[6:0]								Z	DATA[11:0]										

OP[3:0]: "0010" (from EEPROM), "0100" (from Register)

ADDR[6:0]: Register or EEPROM address number (See Address map)

DATA[11:0]: 12-bit data to read

Z: Hi-Z

## 3) Read Angle Data

23	22	21	20	19	18	17	16	15	14	13	12	11	10	9	8	7	6	5	4	3	2	1	0
1	0	0	1	*				Z	P1	P2	E	R_ANG[11:0]											

OP[3:0]: "1001"

R\_ANG[11:0]: 12-bit angle data

P1: Parity bit for R\_ANG[11:6]

P2: Parity bit for R\_ANG[5:0]

E: Error bit for all valid self-diagnosis

Z: Hi-Z

(\*: Don't care)

## 4) Change Mode

23	22	21	20	19	18	17	16	15	14	13	12	11	10	9	8	7	6	5	4	3	2	1	0
0	1	0	1	0	0	0	0	0	1	0	*	R_CHMD[11:0]											

OP[3:0]: "0101"

ADDR[6:0]: "0x02"

R\_CHMD[11:0]: "0x50F" (User Mode), "0x000" (Normal Mode)

(\*: Don't care)

## 5) Soft Reset

23	22	21	20	19	18	17	16	15	14	13	12	11	10	9	8	7	6	5	4	3	2	1	0
0	1	1	0	1	0	0	1	1	1	0	*												

OP[3:0]: "0110"

ADDR[6:0]: "0x4E"

(\*: Don't care)

## 16. Self-diagnostic Function

The AK7401 has several self-diagnostic functions to detect a function failure, a mismatch of EEPROM data and an out-of-range operating condition. In User Mode, each diagnostic function can be disabled but it is strongly recommended to enable all diagnostic functions for the system robustness.

- **Startup Sequence Diagnostic Function**

The AK7401 indicates an error during the startup sequence. This error sets the PWM output to low level and error bit to "0".

- **Mismatch Detection among EEPROM Data**

The AK7401 indicates an error when there is a mismatch of the triple-redundant configuration EEPROM data. This error sets the PWM output to low level and error bit to "0".

- **Mismatch Detection between Transfer Buffer Register and EEPROM Data**

The AK7401 indicates an error when there is a mismatch between the transfer buffer register and the EEPROM data. This error sets the PWM output to low level and error bit to "0".

- **Mismatch Detection between Configuration Register and Transfer Buffer Register**

The AK7401 indicates an error when there is a mismatch between the configuration register and the transfer buffer register. This error sets the PWM output to low level and error bit to "0".

- **Analog Signal Sequence Diagnostic Function**

The AK7401 indicates an error when there is a failure in analog signal processing sequence. This error sets the PWM output to low level and error bit to "0".

- **Under or Over Magnetic Flux Density Detection**

The AK7401 indicates an error when the magnetic flux density is undersupplied (default setting Typ.  $B < 5\text{mT}$ ) or oversupplied (default setting Typ.  $B > 80\text{mT}$ ). This error sets the PWM output to low level and error bit to "0".

- **PWM Duty Over Range Diagnostic Function**

The AK7401 indicates an error when there is a deviation from the normal duty cycle range (10 to 90%). This error sets the PWM output to low level.

- **Configuration Register Reloading Sequence Diagnostic Function**

The AK7401 indicates an error when there is a failure in reloading sequence for the configuration register from EEPROM. This error sets the PWM output to low level and error bit to "0".

- Averaging Data range Diagnostic Function**

The AK7401 indicates an error when the original data set before averaging spread out among three quadrants. This error sets the PWM output level to low and error bit to "0".

It is caused by higher rotation speed than averaging time.

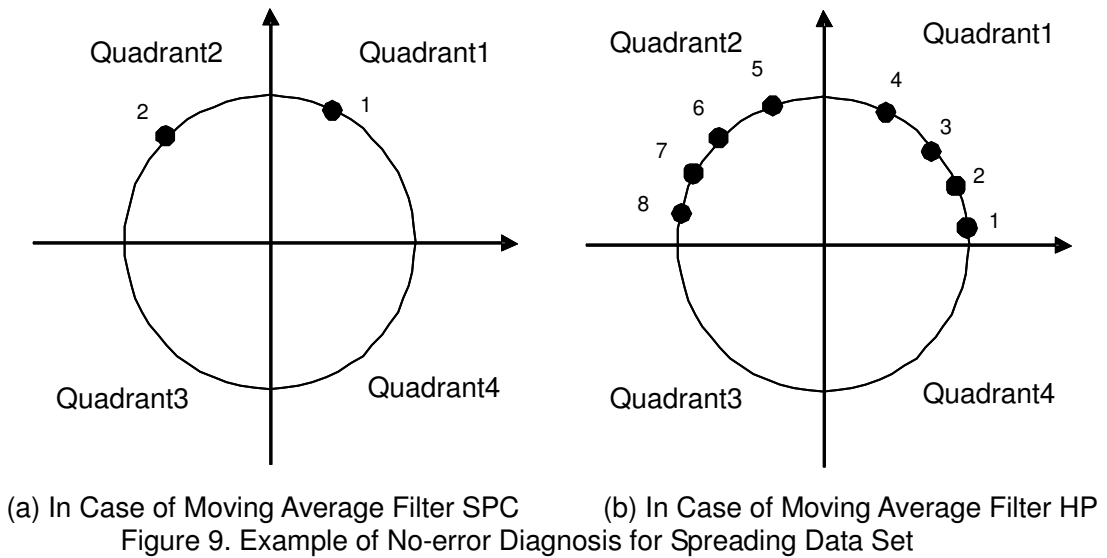
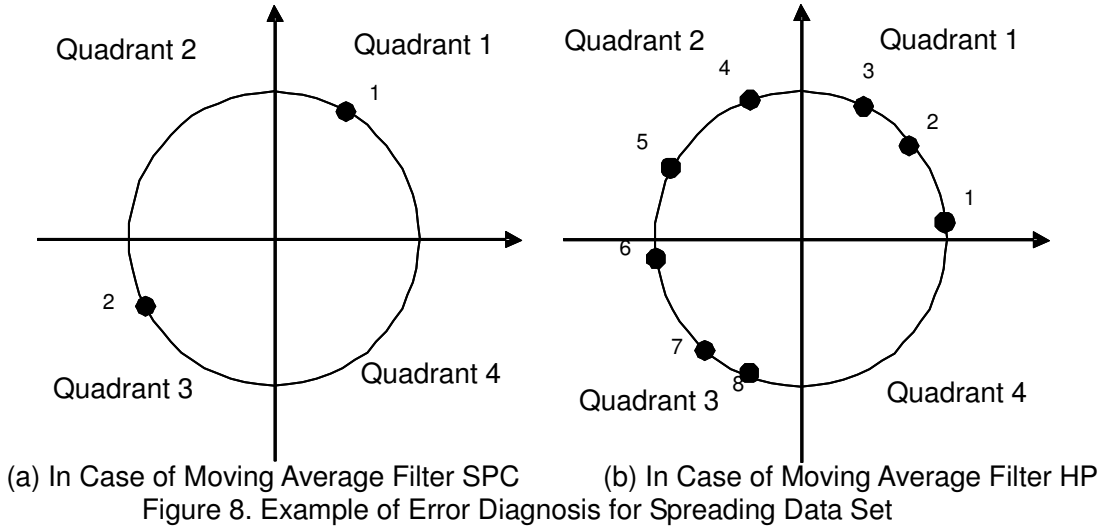

- **EEPROM Write Sequence Diagnostic Function**

The AK7401 indicates an error when there is overtime in the loading sequence for EEPROM (Typ. 6.4ms). This error sets the PWM output to low level and error bit to "0".

- **Under or Over Voltage Supply Detection**

The AK7401 indicates an error when supply voltage is less than under voltage detection level (Typ.  $V_{DD}<3.5V$ ) or supply voltage is more than over voltage detection level (Typ.  $V_{DD}>6.0V$ ). This error sets the PWM output to low level and error bit to "0".

- **Excessive Over Voltage Supply Detection**

The AK7401 indicates an error when supply voltage is more than output shutdown level (Typ.  $V_{DD}>7.3V$ ). This error sets the PWM output to high impedance (Hi-Z) and error bit to "0".

## 17. Register & EEPROM Address Map &Description

- **Register Address Map**

Address	Register Name	Permission		Content
		Normal Mode	User Mode	
0x00	R_ANG[11:0]	R	R	Angle Data
0x01	R_MFDI[7:0]	N/A	R	Magnetic Flux Density Data
0x02	R_CHMD[11:0]	W	R/W	Mode Indicator
0x03	R_MLK[11:0]	N/A	R	Memory Lock Indicator
0x04	R_ID[11:0]	N/A	R/W	Free Bits for User
0x05	R_RD[2:0]	N/A	R/W	Rotation Direction Configuration
0x06	R_ZP[11:0]	N/A	R/W	Zero Degree Point Configuration
0x07	R_ABNRM[11:0]	N/A	R/W	Self-diagnostic Configuration
0x08	R_MFDRH[7:0]	N/A	R/W	Upper Limit of Magnetic Flux Density
0x09	R_MFDRL[7:0]	N/A	R/W	Lower Limit of Magnetic Flux Density
0x0A	R_PWMPL[8:6]	N/A	R/W	PWM Polarity Configuration
	R_PWMF[5:0]			PWM Frequency Configuration
0x0B	R_PWMOMD[2:0]	N/A	R/W	Output Type of the OUT Pin Configuration
0x0C	N/A	N/A	N/A	-
0x0D	R_IT[8:3]	N/A	R/W	Angle Data Averaging Configuration

(N/A: not available, R: read only, W: write only, R/W: full access)

- Register description

### 1) R\_ANG (Addr. 0x00)

DATA[11:0]											
11	10	9	8	7	6	5	4	3	2	1	0
R_ANG[11:0]											

These registers contain the 12-bit angle data. In Normal Mode, R\_ANG can be read via ReadAngle operation code.

### 2) R\_MFDI (Addr. 0x01)

DATA[11:0]											
11	10	9	8	7	6	5	4	3	2	1	0
-				R_MFDI[7:0]							

These registers contain the 8-bit magnetic flux density data. The data resolution is about 1mT. In User Mode, the magnetic flux density can be detected from these registers. When fabricating a rotary position sensor module that uses a magnet and the AK7401, it is able to check the magnetic flux density whether targeted strength is applied or not.

### 3) R\_CHMD (Addr. 0x02)

DATA[11:0]											
11	10	9	8	7	6	5	4	3	2	1	0
R_CHMD[11:0]											

These registers contain the 12-bit mode indication data. In Normal Mode, the mode indication data can be stored in R\_CHMD via ChangeMode operation code.

Operating Mode	R_CHMD[11:0]	Default
Normal Mode	0x000	•
User Mode	0x50F	



**4) R\_MLK (Addr. 0x03)**

DATA[11:0]											
11	10	9	8	7	6	5	4	3	2	1	0
R_MLK[11:0]											

These registers contain the 12-bit memory lock indication data. To check the memory condition, R\_MLK can be read via ReadReg operation code in User Mode.

Memory Condition	R_MLK[11:0]	Default
Unlocked	Except for 0x5A5	•
Locked	0x5A5	

**5) R\_ID(Addr. 0x04)**

DATA[11:0]											
11	10	9	8	7	6	5	4	3	2	1	0
R_ID[11:0]											

These registers contain the 12-bit identification data which is stored in EEPROM for user traceability purpose.

**6) R\_RD (Addr. 0x05)**

DATA[11:0]											
11	10	9	8	7	6	5	4	3	2	1	0
-									R_RD[2:0]		

These registers contain the configuration data of magnet rotation direction. CCW (counter clockwise) is defined by the 1-4-5-8 pin order direction for SOP-8 package top view position. CW (clockwise) is defined by the 8-5-4-1 pin order direction for SOP-8 package top view position.

Rotation Direction	R_RD[2:0]	Default
CCW	0x0	•
CW	0x7	

**7) R\_ZP (Addr. 0x06)**

DATA[11:0]											
11	10	9	8	7	6	5	4	3	2	1	0
R_ZP[11:0]											

These registers contain the configuration data of zero degree point. This data is used as a reference of the 12-bits angle data.

**8) R\_ABNRM (Addr. 0x07)**

DATA[11:0]											
11	10	9	8	7	6	5	4	3	2	1	0
R_ABNRM[11:0]											

These registers contain the configuration data for the self-diagnostic functions. To disable a specific diagnostic function, the corresponding bit should be set to “1”.

R_ABNRM[11:0]	Description	Default
R_ABNRM[11]	Diagnostic for over excessive voltage supply	0
R_ABNRM[10]	Diagnostic for over or under voltage supply	0
R_ABNRM[9]	Diagnostic for EEPROM write sequence	0
R_ABNRM[8]	Diagnostic for dispersion of averaging data set	0
R_ABNRM[7]	Diagnostic for EEPROM reload sequence	0
R_ABNRM[6]	Diagnostic for deviation from normal PWM duty cycle range	0
R_ABNRM[5]	Diagnostic for over or under the magnetic flux density	0
R_ABNRM[4]	Diagnostic for analog signal sequence	0
R_ABNRM[3]	Diagnostic for mismatch between the configuration register and the transfer buffer register	0
R_ABNRM[2]	Diagnostic for mismatch between the transfer buffer register and EEPROM	0
R_ABNRM[1]	Diagnostic for mismatch among the triple-redundant EEPROM	0
R_ABNRM[0]	Diagnostic for IC startup sequence	0

**9) R\_MFDRH (Addr. 0x08)**

DATA[11:0]											
11	10	9	8	7	6	5	4	3	2	1	0
-				R_MFDRH[7:0]							

These registers contain the configuration data for upper limit of the magnetic flux density. This data is used as a reference for the magnetic flux density diagnostics. The default setting is “0x50” (approximately 80mT). The data resolution is about 1mT. R\_MFDRH level should be more than R\_MFDRL level.

**10) R\_MFDRL(Addr. 0x09)**

DATA[11:0]											
11	10	9	8	7	6	5	4	3	2	1	0
-				R_MFDRL[7:0]							

These registers contain the configuration data for lower limit of the magnetic flux density. This data is used as a reference for the magnetic flux density diagnostics. The default setting is “0x05” (approximately 5mT). The data resolution is about 1mT. R\_MFDRL level should be less than R\_MFDRH level.

**11) R\_PWMF, R\_PWMPL (Addr. 0x0A)**

DATA[11:0]											
11	10	9	8	7	6	5	4	3	2	1	0
-			R_PWMPL[2:0]			R_PWMF[5:0]					

These registers contain the configuration data for PWM frequency and polarity.  
 In plus polarity, PWM duty increases according to angle data increase.  
 In minus polarity, PWM duty increases according to angle data decrease.

PWM Polarity	R_PWMPL[2:0]	Default
Plus	0x0	•
Minus	0x7	

PWM Frequency [Hz]	R_PWMF[5:0]	Default
1000	0x00	•
500	0x07	
250	0x3F	

**12) R\_PWMOMD (Addr. 0x0B)**

DATA[11:0]											
11	10	9	8	7	6	5	4	3	2	1	0
-									R_PWMOMD[2:0]		

These registers contain the configuration data of the output type for the OUT pin.  
 The output type configuration of the OUT pin provides Push-pull and NMOS-open-drain.

PWM output type	R_PWMOMD[2:0]	Default
Push-pull	0x0	•
NMOS-open-drain	0x7	

**13) R\_IT (Addr. 0x0D)**

DATA[11:0]											
11	10	9	8	7	6	5	4	3	2	1	0
-			R_IT[5:0]						-		

These registers contain the configuration data for moving average filter.  
 The configuration of moving average filter provides **SPC** (2 times averaging), **HP** (8 times averaging) and **OFF** (without averaging procedure).

Average filter	R_IT[5:0]	Default
SPC	0x00	•
HP	0x07	
OFF	0x3F	

● EEPROM Address Map

Address	EEPROM Name	Permission		Content
		Normal Mode	User Mode	
0x00	MEM_0[11:0]	N/A	N/A	AKM reserved
0x01	MEM_1[11:0]		N/A	AKM reserved
0x02	MEM_2[11:0]		N/A	AKM reserved
0x03	E_MLK[11:0]		R/W	Memory Lock Key
0x04	E_ID[11:0]		R/W	Free EEPROM for User
0x05	MEM_5[11:3]		N/A	AKM reserved
	E_RD[2:0]		R/W	Rotation Direction Configuration
0x06	E_ZP[11:0]		R/W	Zero Degree Point Configuration
0x07	E_ABNRM[11:0]		R/W	Self-diagnostic Configuration
0x08	MEM_8[11:8]		N/A	AKM reserved
	E_MFDRH[7:0]		R/W	Upper Limit of Magnetic Flux Density
0x09	MEM_9[11:8]		N/A	AKM reserved
	E_MFDRL[7:0]		R/W	Lower Limit of Magnetic Flux Density
0x0A	MEM_A[11:9]		N/A	AKM reserved
	E_PWMPL[8:6]		R/W	PWM Polarity Configuration
	E_PWMF[5:0]		R/W	PWM Frequency Configuration
0x0B	MEM_B[11:3]	N/A	AKM reserved	
	E_PWMOMD[2:0]	R/W	Output Type of the OUT Pin Configuration	
0x0C	MEM_C[11:0]	N/A	AKM reserved	
0x0D	MEM_D[11:9]	N/A	AKM reserved	
	E_IT[8:3]	R/W	Angle Data Averaging Configuration	
	MEM_D[2:0]	N/A	AKM reserved	
0x0E to 0x3F	-	N/A	R	AKM reserved

(N/A: not available, R: read only, W: write only, R/W: full access)

● EEPROM Description

1) E\_MLK (Addr. 0x03)

DATA[11:0]											
11	10	9	8	7	6	5	4	3	2	1	0
E_MLK[11:0]											

These EEPROM contain the 12-bit memory lock key data. To prevent EEPROM from rewriting incorrectly, the memory lock key data can be stored in E\_MLK via WriteEEPROM operation code in User Mode.

Memory Condition	E_MLK[11:0]	Default
Unlocked	Except for 0x5A5	●(0x000)
Locked	0x5A5	

**2) E\_ID(Addr. 0x04)**

DATA[11:0]											
11	10	9	8	7	6	5	4	3	2	1	0
E_ID[11:0]											

These EEPROM can use freely for traceability purpose.

**3) E\_RD (Addr. 0x05)**

DATA[11:0]											
11	10	9	8	7	6	5	4	3	2	1	0
-									E_RD[2:0]		

These EEPROM contain the configuration data for magnet rotation direction. To validate the user configuration in Normal Mode, store the configuration data in E\_RD via WriteEEPROM operational code in User Mode.

CCW (counter clockwise) is defined by 1-4-5-8 pin order direction for SOP-8 package top view position.  
CW (clockwise) is defined by 8-5-4-1 pin order direction for SOP-8 package top view position.

Rotation Direction	E_RD[2:0]	Default
CCW	0x0	•
CW	0x7	

WARNING: If data except "0x0" and "0x7" is set to E\_RD[2:0], the rotation direction can not be guaranteed.

**4) E\_ZP (Addr. 0x06)**

DATA[11:0]											
11	10	9	8	7	6	5	4	3	2	1	0
E_ZP[11:0]											

These EEPROM contain the configuration data for the zero degree point. This data is used as a reference of the 12-bit angle data. To validate the user configuration in Normal Mode, store the configuration data in E\_ZP via WriteEEPROM operation code in User Mode.

**5) E\_ABNRM (Addr. 0x07)**

DATA[11:0]											
11	10	9	8	7	6	5	4	3	2	1	0
E_ABNRM[11:0]											

These EEPROM contain the configuration data for self-diagnostic functions. To inactivate a specific diagnostic function, the corresponding bit should be set to "1". To validate the user configuration in Normal Mode, store the configuration data to E\_ABNRM via WriteEEPROM operation code in User Mode.

E_ABNRM[11:0]	Description	Default
E_ABNRM[11]	Diagnostic for over excessive voltage supply	0
E_ABNRM[10]	Diagnostic for over or under voltage supply	0
E_ABNRM[9]	Diagnostic for EEPROM write sequence	0
E_ABNRM[8]	Diagnostic for dispersion of averaging data set	0
E_ABNRM[7]	Diagnostic for EEPROM reload sequence	0
E_ABNRM[6]	Diagnostic for deviation from normal PWM duty cycle range	0
E_ABNRM[5]	Diagnostic for over or under the magnetic flux density supply	0
E_ABNRM[4]	Diagnostic for analog signal sequence	0
E_ABNRM[3]	Diagnostic for mismatch between the configuration register and the transfer buffer register	0
E_ABNRM[2]	Diagnostic for mismatch between the transfer buffer register and EEPROM	0
E_ABNRM[1]	Diagnostic for mismatch among the triple-redundant EEPROM	0
E_ABNRM[0]	Diagnostic for IC startup sequence	0

**6) E\_MFDRH (Addr. 0x08)**

DATA[11:0]											
11	10	9	8	7	6	5	4	3	2	1	0
-				E_MFDRH[7:0]							

These EEPROM contain the configuration data for upper limit of the magnetic flux density. This data is used as a reference for magnetic flux density diagnostics. To validate the user configuration in Normal Mode, store the configuration data to E\_MFDRH via WriteEEPROM operation code in User Mode. The default setting is "0x50" (approximately 80mT). The data resolution is about 1mT. E\_MFDRH level should be more than E\_MFDRL level.

**7) E\_MFDRL (Addr. 0x09)**

DATA[11:0]											
11	10	9	8	7	6	5	4	3	2	1	0
-				E_MFDRL[7:0]							

These EEPROM contain the configuration data for upper limit of the magnetic flux density. This data is used as a reference for magnetic flux density diagnostics. To validate the user configuration in Normal Mode, store the configuration data to E\_MFDRL via WriteEEPROM operation code in User Mode. The default setting is "0x05" (approximately 05mT). The data resolution is about 1mT. E\_MFDRL level should be less than E\_MFDRH level.

**8) E\_PWMF, E\_PWMPL (Addr. 0x0A)**

DATA[11:0]											
11	10	9	8	7	6	5	4	3	2	1	0
-				E_PWMPL[2:0]			E_PWMF[5:0]				

These EEPROM contain the configuration data for PWM frequency and polarity. To validate the user configuration in Normal Mode, store the configuration data to E\_PWMPL and E\_PWMF via WriteEEPROM operation code in User Mode.

In plus polarity, PWM duty increases according to angle data increase.

In minus polarity, PWM duty increases according to angle data decrease.

PWM Polarity	E_PWMPL[2:0]	Default
plus	0x0	•
minus	0x7	

WARNING: If a data except "0x0" and "0x7" is set to E\_PWMPL[2:0] bits, PWM polarity can not be guaranteed.

PWM Frequency [Hz]	E_PWMF[5:0]	Default
1000	0x00	•
500	0x07	
250	0x3F	

WARNING: If a data except "0x0", "0x7" and "0x3F" is set to E\_PWMF[5:0] bits, PWM frequency can not be guaranteed.

**9) E\_PWMOMD (Addr. 0x0B)**

DATA[11:0]											
11	10	9	8	7	6	5	4	3	2	1	0
-									E_PWMOMD[2:0]		

These EEPROM contain the configuration data of output type for the OUT pin. The output type configuration of the OUT pin provides Push-pull and NMOS-open-drain. To validate the user configuration in Normal Mode, store the configuration data to E\_PWMOMD via WriteEEPROM operation code in User Mode.

OUT pin output type	E_PWMOMD[2:0]	Default
Push-Pull	0x0	•
NMOS-Open-Drain	0x7	

**WARNING:** If a data except "0x0" and "0x7" is set to E\_PWMOMD[2:0] bits, the OUT pin output type can not be guaranteed.

**9) E\_IT (Addr. 0x0D)**

DATA[11:0]											
11	10	9	8	7	6	5	4	3	2	1	0
-					E_IT[5:0]					-	

These EEPROM contain the configuration data for the moving average filter of processing angle data. The configuration of the moving average filter provides **SPC** (2 times averaging), **HP** (8 times averaging) and **OFF** (without averaging procedure). To validate the user configuration in Normal Mode, store the configuration data to E\_IT via WriteEEPROM operation code in User Mode.

Average filter	E_IT[5:0]	Default
SPC	0x00	•
HP	0x07	
OFF	0x3F	

**WARNING:** If a data except "0x0", "0x7" and "0x3F" is set to E\_IT[5:0] bits, the moving average filter can not be guaranteed.



## 18. Default Settings Information

The AK7401 default settings are as below.

### 1. Zero Degree Point

Figure 10 shows the default relationship between the magnet placement and the zero degree point.

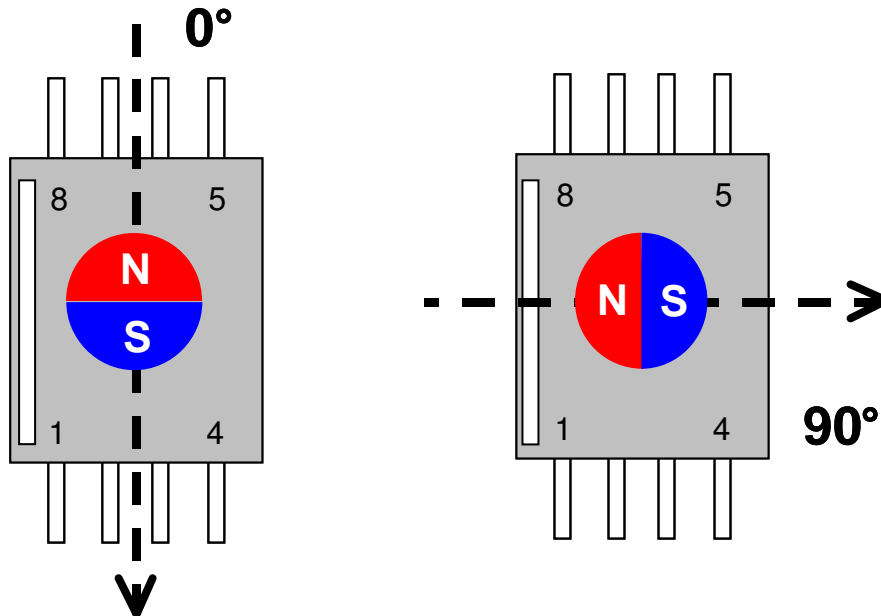

Figure 10. Default Angle Setting

### 2. Magnet Rotation Direction

Figure 10 shows the default magnet rotation direction. The default setting is counter clock-wise (CCW).

CCW is defined by the 1-4-5-8 pin order direction for SOP-8 package top view position.

### 3. Over and Under Magnetic Flux Density Limit

The default setting of upper limit of the magnetic flux density is approximately 80mT and under limit is 5mT.

### 4. PWM Frequency

The default setting is 1000Hz.

### 5. PWM Polarity

The default setting is plus polarity.

In plus polarity settings, the highest angle data corresponds to maximum PWM duty.

### 6. Output Setting of the OUT Pin

The default setting is Push-Pull output type.

### 7. Self-diagnostic Configuration

The default setting is all valid diagnostic function.

### 8. Memory Lock

The default setting is unlocked.

**19. Recommended External Circuit**

It is recommended to use 100nF decoupling capacitors.

The TEST0 and TEST1 pins must be open.

When the 3-wire SPI interface is not used, the SCLK and CS pins must be connected to GND and the SIN/SOUT pin must be open.

When PWM interface is not used, the OUT pin must be open.

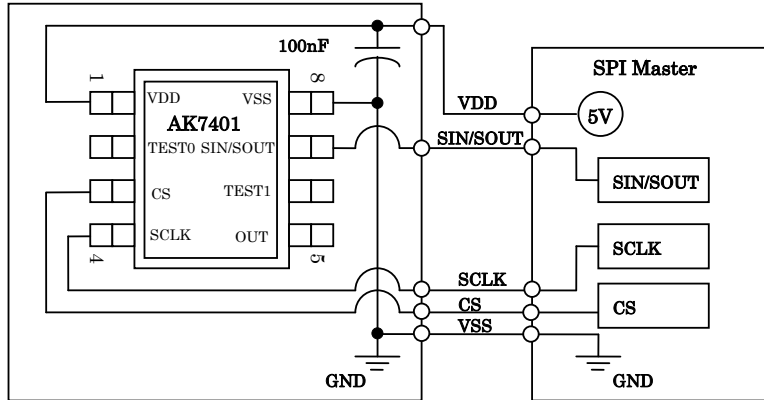

Figure 11. Recommended External Circuit for 3-wire SPI Connection

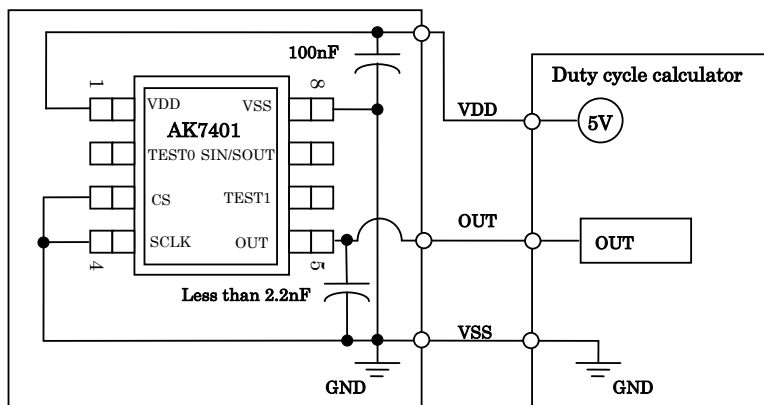
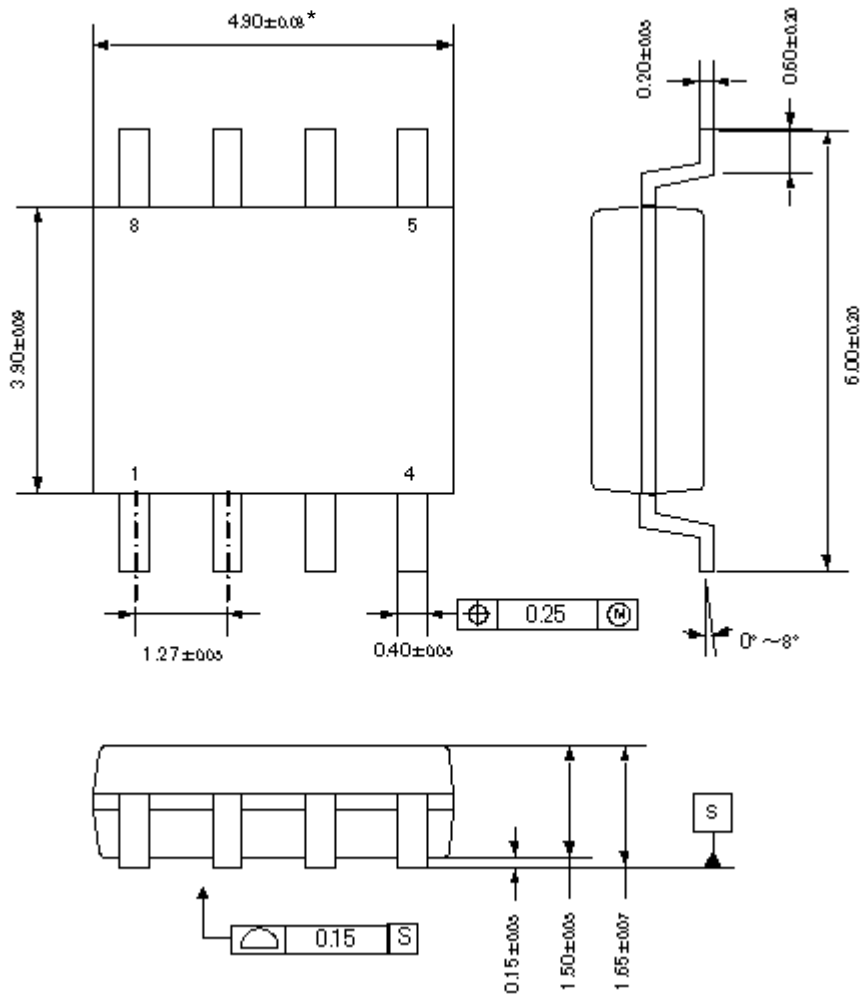

Figure 12. Recommended External Circuit for PWM Connection

20. Package Information

■ Outline Dimensions



\* Dimension does not include mold flush, protrusions or gate burrs.

■ Materials

Molding compound:	Epoxy
Lead frame material:	Cu
Outer lead plating:	Sn-2.5Ag

■ Marking

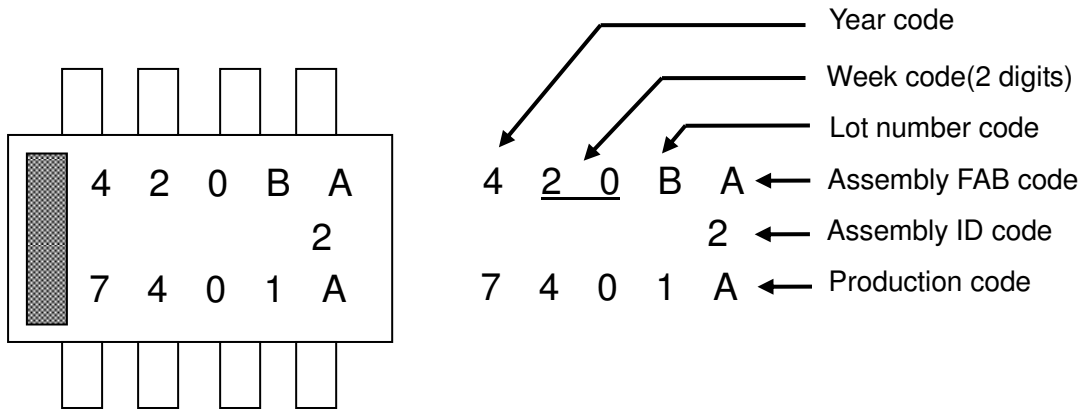

■ Sensitive Area Location

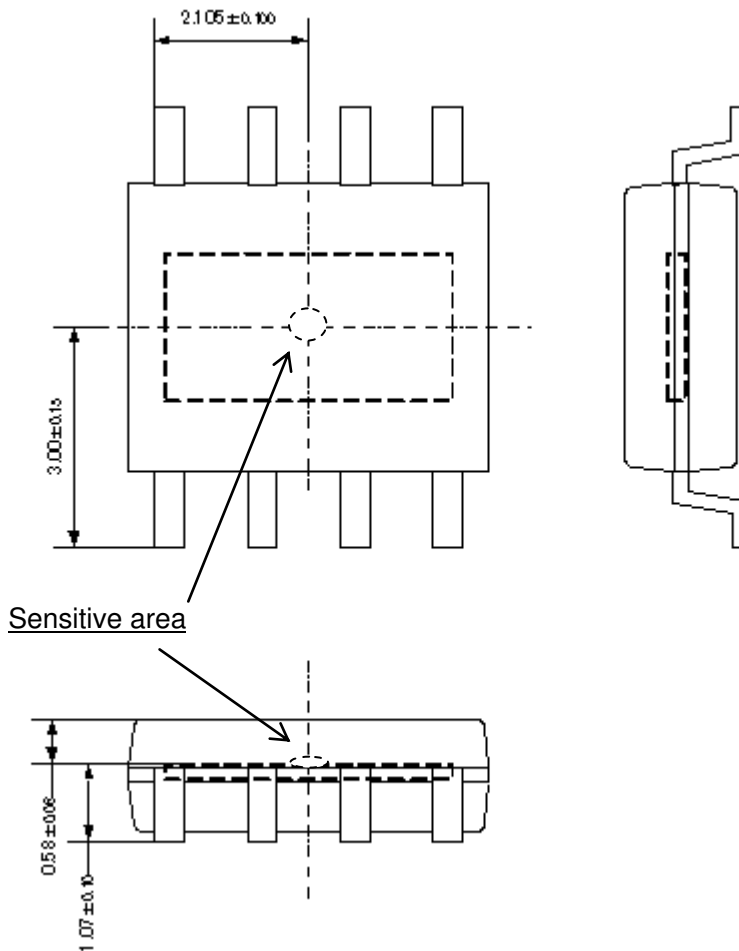

**21. Revision History**

Date (Y/M/D)	Revision	Reason	Page	Contents
15/07/31	01	First Edition		

#### IMPORTANT NOTICE

0. Asahi Kasei Microdevices Corporation (“AKM”) reserves the right to make changes to the information contained in this document without notice. When you consider any use or application of AKM product stipulated in this document (“Product”), please make inquiries the sales office of AKM or authorized distributors as to current status of the Products.
1. All information included in this document are provided only to illustrate the operation and application examples of AKM Products. AKM neither makes warranties or representations with respect to the accuracy or completeness of the information contained in this document nor grants any license to any intellectual property rights or any other rights of AKM or any third party with respect to the information in this document. You are fully responsible for use of such information contained in this document in your product design or applications. **AKM ASSUMES NO LIABILITY FOR ANY LOSSES INCURRED BY YOU OR THIRD PARTIES ARISING FROM THE USE OF SUCH INFORMATION IN YOUR PRODUCT DESIGN OR APPLICATIONS.**
2. The Product is neither intended nor warranted for use in equipment or systems that require extraordinarily high levels of quality and/or reliability and/or a malfunction or failure of which may cause loss of human life, bodily injury, serious property damage or serious public impact, including but not limited to, equipment used in nuclear facilities, equipment used in the aerospace industry, medical equipment, equipment used for automobiles, trains, ships and other transportation, traffic signaling equipment, equipment used to control combustions or explosions, safety devices, elevators and escalators, devices related to electric power, and equipment used in finance-related fields. Do not use Product for the above use unless specifically agreed by AKM in writing.
3. Though AKM works continually to improve the Product’s quality and reliability, you are responsible for complying with safety standards and for providing adequate designs and safeguards for your hardware, software and systems which minimize risk and avoid situations in which a malfunction or failure of the Product could cause loss of human life, bodily injury or damage to property, including data loss or corruption.
4. Do not use or otherwise make available the Product or related technology or any information contained in this document for any military purposes, including without limitation, for the design, development, use, stockpiling or manufacturing of nuclear, chemical, or biological weapons or missile technology products (mass destruction weapons). When exporting the Products or related technology or any information contained in this document, you should comply with the applicable export control laws and regulations and follow the procedures required by such laws and regulations. The Products and related technology may not be used for or incorporated into any products or systems whose manufacture, use, or sale is prohibited under any applicable domestic or foreign laws or regulations.
5. Please contact AKM sales representative for details as to environmental matters such as the RoHS compatibility of the Product. Please use the Product in compliance with all applicable laws and regulations that regulate the inclusion or use of controlled substances, including without limitation, the EU RoHS Directive. AKM assumes no liability for damages or losses occurring as a result of noncompliance with applicable laws and regulations.
6. Resale of the Product with provisions different from the statement and/or technical features set forth in this document shall immediately void any warranty granted by AKM for the Product and shall not create or extend in any manner whatsoever, any liability of AKM.
7. This document may not be reproduced or duplicated, in any form, in whole or in part, without prior written consent of AKM.