

# ISD Cortex™-M0 ChipCorder

## ISD9100 Series

### Datasheet

The information described in this document is the exclusive intellectual property of Nuvoton Technology Corporation and shall not be reproduced without permission from Nuvoton.

Nuvoton is providing this document only for reference purposes of ISD ChipCorder microcontroller based system design. Nuvoton assumes no responsibility for errors or omissions.

All data and specifications are subject to change without notice.

For additional information or questions, please contact: Nuvoton Technology Corporation.

Publication Release Date: Oct 24, 2014  
Revision V1.30

**Table of Contents-**

	TABLE OF CONTENTS- .....	2
1	GENERAL DESCRIPTION .....	3
2	FEATURES .....	4
3	PART INFORMATION AND PIN CONFIGURATION .....	7
3.1	Pin Configuration .....	7
3.1.1	ISD9100 LQFP 48 pin.....	7
3.1.2	Pin Description.....	7
4	BLOCK DIAGRAM .....	12
5	APPLICATION DIAGRAM.....	13
6	ELECTRICAL CHARACTERISTICS .....	14
6.1	Absolute Maximum Ratings .....	14
6.2	DC Electrical Characteristics .....	15
6.3	AC Electrical Characteristics .....	19
6.3.1	External 32kHz XTAL Oscillator.....	19
6.3.2	Internal 49.152MHz Oscillator.....	19
6.3.3	Internal 16 kHz Oscillator.....	19
6.3.4	Reset Characteristics.....	19
7	PACKAGE DIMENSIONS .....	21
7.1.1	48L LQFP (7x7x1.4mm footprint 2.0mm).....	21
8	ORDERING INFORMATION.....	22
9	REVISION HISTORY .....	23
	<b>IMPORTANT NOTICE</b> .....	24

## 1 GENERAL DESCRIPTION

The ISD9100 is a system-on-chip product optimized for low power, audio record and playback with an embedded ARM® Cortex™-M0 32-bit microcontroller core.

The ISD9100 embeds a Cortex™-M0 core running up to 49 MHz with 68/100/145K-byte of non-volatile flash memory and 12K-byte of embedded SRAM. It also comes equipped with a variety of peripheral devices, such as Timers, Watchdog Timer (WDT), Real-time Clock (RTC), Peripheral Direct Memory Access (PDMA), a variety of serial interfaces (UART, SPI/SSP, I<sup>2</sup>C, I<sup>2</sup>S), PWM modulators, GPIO, Analog Comparator, Low Voltage Detector and Brown-out detector.

The ISD9100 comes equipped with a rich set of power saving modes including a Deep Power Down (DPD) mode drawing less than 1μA. A micro-power 16KHz oscillator can periodically wake up the device from deep power down to check for other events. A Standby Power Down (SPD) mode can maintain a real time clock function at less than 10 μA.

For audio functionality the ISD9100 includes a Sigma-Delta ADC with 92dB SNR performance coupled with a Programmable Gain Amplifier (PGA) capable of a maximum gain of 61dB to enable direct connection of a microphone. Audio output is provided by a Differential Class D amplifier (DPWM) that can deliver 1W<sup>1</sup> of power to an 8Ω speaker.

The ISD9100 provides eight analog enabled general purpose IO pins (GPIO). These pins can be configured to connect to an analog comparator, can be configured as analog current sources or can be routed to the SDADC for analog conversion. They can also be used as a relaxation oscillator to perform capacitive touch sensing.

---

<sup>1</sup> We suggest implementing thermal protection by utilizing the Temperature Alarm; for details please refer to Temperature Alarm in Design Guide.

## 2 FEATURES

- Core
  - ARM® Cortex™-M0 core runs up to 49MHz.
  - One 24-bit System tick timer for operating system support.
  - Supports a variety of low power sleep and power down modes.
  - Single-cycle 32-bit hardware multiplier.
  - NVIC (Nested Vector Interrupt Controller) for 32 interrupt inputs, each with 4-levels of priority.
  - Serial Wire Debug (SWD) support with 2 watchpoints/4 breakpoints.
- Power Management
  - Wide operating voltage range from 2.4V to 5.5V.
  - Power management Unit (PMU) providing four levels of power control.
  - Deep Power Down (DPD) mode with sub micro-amp leakage (<1μA).
  - Wakeup from Deep Power Down via dedicated WAKEUP pin or timed operation from internal low power 16kHz oscillator.
  - Standby mode with limited RAM retention and RTC operation (<10μA).
  - Wakeup from Standby can be from any GPIO interrupt, RTC or BOD.
  - Sleep mode with minimal dynamic power consumption.
  - 3V LDO for operation of external 3V devices such as serial flash.
- Flash EPROM Memory
  - 68/100/145K bytes Flash EPROM for program code and data storage.
  - 4KB of flash can be configured as boot sector for ISP loader.
  - Support In-system program (ISP) and In-circuit program (ICP) application code update
  - 1K byte page erase for flash
  - Configurable boundary to delineate code and data flash.
  - Support 2 wire In-circuit Programming (ICP) update from SWD ICE interface
- SRAM Memory
  - 12K bytes embedded SRAM.
- Clock Control
  - One high speed and two low speed oscillators providing flexible selection for different applications. No external components necessary.
  - Built-in trimmable oscillator with range of 16-49MHz. Factory trimmed within 1% to settings of 49.152MHz and 32.768MHz. User trimmable with in-built frequency measurement block (OSCFM) using reference clock of 32kHz crystal or external reference source.
  - Ultra-low power (<1uA) 16kHz oscillator for watchdog and wakeup from power-down or sleep operation.
  - External 32kHz crystal input for RTC function and low power system operation.
- GPIO
  - Four I/O modes:
    - ◆ Quasi bi-direction
    - ◆ Push-Pull output
    - ◆ Open-Drain output
    - ◆ Input only with high impedance
  - TTL/Schmitt trigger input selectable.
  - I/O pin can be configured as interrupt source with edge/level setting.
  - Switchable pull-up.
- Audio Analog to Digital converter
  - Sigma Delta ADC with configurable decimation filter and 16 bit output.
  - 92dB Signal-to-Noise (SNR) performance.
  - Programmable gain amplifier with 32 steps from -12 to 35.25dB in 0.75dB steps.
  - Boost gain stage of 26dB, giving maximum total gain of 61dB.

- Input selectable from dedicated MIC pins or analog enabled GPIO.
- Programmable biquad filter to support multiple sample rates from 8-32kHz.
- DMA support for minimal CPU intervention.
- Differential Audio PWM Output (DPWM)
  - Direct connection of speaker
  - 1W drive capability into 8Ω load.
  - High efficiency 88%
  - Configurable up-sampling to support sample rates from 8-32kHz.
  - DMA support for minimal CPU intervention.
- Timers
  - Two timers with 8-bit pre-scaler and 24-bit resolution.
  - Counter auto reload.
- Watch Dog Timer
  - Default ON/OFF by configuration setting
  - Multiple clock sources
  - 8 selectable time out period from micro seconds to seconds (depending on clock source)
  - WDT can wake up power down/sleep.
  - Interrupt or reset selectable on watchdog time-out.
- RTC
  - Real Time Clock counter (second, minute, hour) and calendar counter (day, month, year)
  - Alarm registers (second, minute, hour, day, month, year)
  - Selectable 12-hour or 24-hour mode
  - Automatic leap year recognition
  - Time tick and alarm interrupts.
  - Device wake up function.
  - Supports software compensation of crystal frequency by compensation register (FCR)
- PWM/Capture
  - Built-in up to two 16-bit PWM generators provide two PWM outputs or one complementary paired PWM outputs.
  - The PWM generator equipped with a clock source selector, a clock divider, an 8-bit pre-scaler and Dead-Zone generator for complementary paired PWM.
  - PWM interrupt synchronous to PWM period.
  - 16-bit digital Capture timers (shared with PWM timers) provide rising/falling capture inputs.
  - Support Capture interrupt
- UART
  - UART ports with flow control (TX, RX, CTS and RTS)
  - 8-byte FIFO.
  - Support IrDA (SIR) and LIN function
  - Programmable baud-rate generator up to 1/16 of system clock.
- SPI
  - Master up to 20 Mbps / Slave up to 10 Mbps.
  - Support MICROWIRE/SPI master/slave mode (SSP)
  - Full duplex synchronous serial data transfer
  - Variable length of transfer data from 1 to 32 bits
  - MSB or LSB first data transfer
  - 2 slave/device select lines when used in master mode.
  - Hardware CRC calculation module available for CRC calculation of data stream.
  - DMA support for burst transfers.
- I2C
  - Master/Slave up to 1Mbit/s
  - Bidirectional data transfer between masters and slaves
  - Multi-master bus (no central master).



- Arbitration between simultaneously transmitting masters without corruption of ser the bus
- Serial clock synchronization allows devices with different bit rates to communicate via one serial bus.
- Serial clock synchronization can be used as a handshake mechanism to suspend and resume serial transfer.
- Programmable clock allowing versatile rate control.
- I2C-bus controller supports multiple address recognition.
- I<sup>2</sup>S
  - Interface with external audio CODEC.
  - Operate as either master or slave.
  - Capable of handling 8, 16, 24 and 32 bit word sizes
  - Mono and stereo audio data supported
  - I<sup>2</sup>S and MSB justified data format supported
  - Two 8 word FIFO data buffers are provided, one for transmit and one for receive
  - Generates interrupt requests when buffer levels cross a programmable boundary
  - Supports DMA requests, for transmit and receive
- Brown-out detector
  - With 8 levels: 2.1V, 2.2V, 2.4V, 2.5V, 2.625V, 2.8V, 3.0V, and 4.6V
  - Supports time-multiplex operation to minimize power consumption.
  - Supports Brownout Interrupt and Reset option
- Built in Low Dropout Voltage Regulator (LDO)
  - Capable of delivering 30mA load current.
  - Configurable for output voltage of 1.8V, 2.4V, 3.0V and 3.3V
  - Eight GPIO (GPIOA<7:0>) operate from LDO voltage domain allowing direct interface to, for example, 3V SPI Flash.
  - Can be bypassed and voltage domain supplied directly from system power.
- Additional Features
  - Over temperature alarm. Can generate interrupt if device exceeds safe operating temperature.
  - Temperature proportional voltage source which can be routed to ADC for temperature measurements.
  - Digital Microphone interface.
- Operating Temperature: -40C~85C
- Package:
  - All Green package (RoHS)
    - ◆ LQFP 48-pin

### 3 PART INFORMATION AND PIN CONFIGURATION

#### 3.1 Pin Configuration

##### 3.1.1 ISD9100 LQFP 48 pin

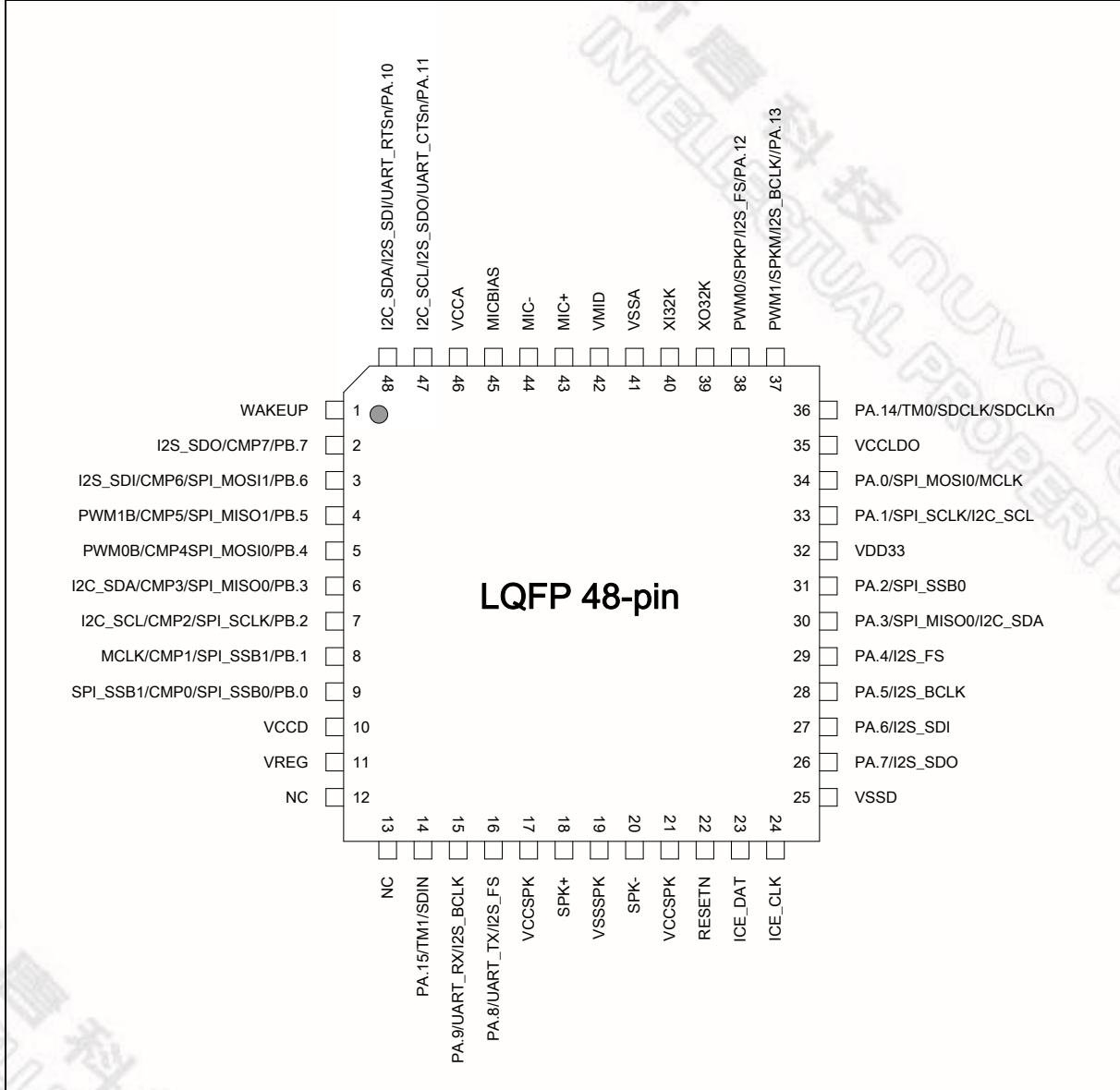

##### 3.1.2 Pin Description

The ISD9100 is a low pin count device where many pins are configurable to alternative functions. All General Purpose Input/Output (GPIO) pins can be configured to alternate functions as described in the table below.

Pin No.	Pin Name	Pin Type	Alt CFG	Description
LQFP 48				

Pin No.	Pin Name	Pin Type	Alt CFG	Description
LQFP 48				
1	WAKEUP	I		Pull low to wake part from deep power down
2	PB.7	A/I/O	0	General purpose input/output pin, analog capable; Port B, bit 7
	I2S_SDO	O	1	Serial Data Output for I2S interface
	CMP7	AIO	2	Configure as relaxation oscillator for capacitive touch sensing
3	PB.6	A/I/O	0	General purpose input/output pin, analog capable; Port B, bit 6
	I2S_SDI	I	1	Serial Data Input for I2S interface
	CMP6	AIO	2	Configure as relaxation oscillator for capacitive touch sensing
	SPI_MOSI1	O	3	Master Out, Slave In channel 1 for SPI interface
4	PB.5	A/I/O	0	General purpose input/output pin, analog capable; Port B, bit 5
	PWM1B	O	1	PWM channel 1 complementary output pin
	CMP5	AIO	2	Configure as relaxation oscillator for capacitive touch sensing
	SPI_MISO1	I	3	Master In, Slave Out channel 1 for SPI interface
5	PB.4	A/I/O	0	General purpose input/output pin, analog capable; Port B, bit 4
	PWM0B	O	1	PWM channel 0 complementary output pin
	CMP4	AIO	2	Configure as relaxation oscillator for capacitive touch sensing
	SPI_MOSI0	O	3	Master Out, Slave In channel 0 for SPI interface
6	PB.3	A/I/O	0	General purpose input/output pin, analog capable; Port B, bit 3
	I2C_SDA	I/O	1	Serial Data, I2C interface
	CMP3	AIO	2	Configure as relaxation oscillator for capacitive touch sensing
	SPI_MISO0	I	3	Master In, Slave Out channel 0 for SPI interface
7	PB.2	A/I/O	0	General purpose input/output pin, analog capable; Port B, bit 2
	I2C_SCL	I/O	1	Serial Clock, I2C interface
	CMP2	AIO	2	Configure as relaxation oscillator for capacitive touch sensing
	SPI_SCLK	I/O	3	Serial Clock for SPI interface
8	PB.1	A/I/O	0	General purpose input/output pin, analog capable; Port B, bit 1. Triggers external interrupt 1 (EINT1/IRQ3)
	MCLK	O	1	Master clock output for synchronizing external device
	CMP1	AIO	2	Configure as relaxation oscillator for capacitive touch sensing
	SPI_SSB1	O	3	Slave Select Bar 1 for SPI interface
9	PB.0	A/I/O	0	General purpose input/output pin, analog capable; Port B, bit 0. Triggers external interrupt 0 (EINT0/IRQ2)
	SPI_SSB1	O	3	Slave Select Bar 1 for SPI interface



Pin No.	Pin Name	Pin Type	Alt CFG	Description
	CMP0	<b>AIO</b>	2	Configure as relaxation oscillator for capacitive touch sensing
	SPI_SSB0	<b>I/O</b>	3	Slave Select Bar 0 for SPI interface
10	VCCD	<b>P</b>		Main Digital Supply for Chip. Supplies all IO except analog, Speaker Driver and PA<7:0>
11	VREG	<b>P</b>		Logic regulator output decoupling pin. A 1µF capacitor returning to VSSD must be placed on this pin.
12	NC			Should remain unconnected.
13	NC			Should remain unconnected.
14	PA.15	<b>I/O</b>	0	General purpose input/output pin; Port A, bit 15
	TM1	<b>I</b>	1	External input to Timer 1
	SDIN	<b>I</b>	2	Sigma Delta bit stream input for digital MIC mode
15	PA.9	<b>I/O</b>	0	General purpose input/output pin; Port A, bit 9
	UART_RX	<b>I</b>	1	Receive channel of UART
	I2S_BCLK	<b>I/O</b>	2	Bit Clock for I2S interface
16	PA.8	<b>I/O</b>	0	General purpose input/output pin; Port A, bit 8
	UART_TX	<b>O</b>	1	Transmit channel of UART
	I2S_FS	<b>I/O</b>	2	Frame Sync Clock for I2S interface
17	VCCSPK	<b>P</b>		Power Supply for PWM Speaker Driver
18	SPK+	<b>O</b>		Positive Speaker Driver Output
19	VSSSPK	<b>P</b>		Ground for PWM Speaker Driver
20	SPK-	<b>O</b>		Negative Speaker Driver Output
21	VCCSPK	<b>P</b>		Power Supply for PWM Speaker Driver
22	RESETN	<b>I</b>		External reset input. Pull this pin low to reset device to initial state. Has internal weak pull-up.
23	ICE_DAT	<b>I/O</b>		Serial Wire Debug port data pin. Has internal weak pull-up.
24	ICE_CLK	<b>I</b>		Serial Wire Debug port clock pin. Has internal weak pull-up.
25	VSSD	<b>P</b>		Digital Ground.
26	PA.7	<b>I/O</b>	0	General purpose input/output pin; Port A, bit 7
	I2S_SDO	<b>O</b>	1	Serial Data Out for I2S interface
27	PA.6	<b>I/O</b>	0	General purpose input/output pin; Port A, bit 6
	I2S_SDI	<b>I</b>	1	Serial Data In for I2S interface
28	PA.5	<b>I/O</b>	0	General purpose input/output pin; Port A, bit 5
	I2S_BCLK	<b>I/O</b>	1	Bit Clock for I2S interface

Pin No.	Pin Name	Pin Type	Alt CFG	Description
LQFP 48				
29	PA.4	I/O	0	General purpose input/output pin; Port A, bit 4
	I2S_FS	I/O	1	Frame Sync Clock for I2S interface
30	PA.3	I/O	0	General purpose input/output pin; Port A, bit 3
	SPI_MISO0	I	1	Master In, Slave Out channel 0 for SPI interface
	I2C_SDA	I/O	2	Serial Data, I2C interface
31	PA.2	I/O	0	General purpose input/output pin; Port A, bit 2
	SPI_SSB0	I/O	1	Slave Select Bar 0 for SPI interface
32	VDD33	P		LDO Regulator Output. If used, a 1µF capacitor must be placed to ground. If not used then tie to VCCD.
33	PA.1	I/O	0	General purpose input/output pin; Port A, bit 1
	SPI_SCLK	I/O	1	Serial Clock for SPI interface
	I2C_SCL	I/O	2	Serial Clock, I2C interface
34	PA.0	I/O	0	General purpose input/output pin; Port A, bit 2
	SPI_MOSI0	O	1	Master Out, Slave In channel 0 for SPI interface
	MCLK	O	2	Master clock output.
35	VCCLDO	P		Power Supply for LDO, should be connected to VCCD
36	PA.14	I/O	0	General purpose input/output pin; Port A, bit 14
	SDCLK	O	1	Clock output for digital microphone mode.
	SDCLKn	O	2	Inverse Clock output for digital microphone mode.
37	PA.13	I/O	0	General purpose input/output pin; Port A, bit 13
	PWM1	O	1	PWM1 Output.
	SPKM	O	2	Equivalent to SPK-.
	I2S_BCLK	I/O	3	Bit Clock for I2S interface
38	PA.12	I/O	0	General purpose input/output pin; Port A, bit 12
	PWM0	O	1	PWM0 Output.
	SPKP	O	2	Equivalent to SPK+
	I2S_FS	I/O	3	Frame Sync Clock for I2S interface
39	XO32K	O		32.768kHz Crystal Oscillator Output
40	XI32K	I		32.768kHz Crystal Oscillator Input. Max Voltage 1.8V
41	VSSA	AP		Ground for analog circuitry.
42	VMID	O		Mid rail reference. Connect 4.7µF to VSSA.
43	MIC+	AI		Positive microphone input.

Pin No.	Pin Name	Pin Type	Alt CFG	Description
<b>LQFP 48</b>				
44	MIC-	<b>AI</b>		Negative microphone input.
45	MICBIAS	<b>AO</b>		Microphone bias output.
46	VCCA	<b>AP</b>		Analog power supply.
47	PA.11	<b>I/O</b>	0	General purpose input/output pin; Port A, bit 11
	I2C_SCL	<b>I/O</b>	1	Serial Clock, I2C interface
	I2S_SDO	<b>O</b>	2	Serial Data Out I2S interface
	UART_CTSn	<b>I</b>	3	UART Clear to Send Input.
48	PA.10	<b>I/O</b>	0	General purpose input/output pin; Port A, bit 10
	I2C_SDA	<b>I/O</b>	1	Serial Data, I2C interface
	I2S_SDI	<b>I</b>	2	Serial Data In I2S interface
	UART_RTSn	<b>O</b>	3	UART Request to Send Output.

**Note:**

- Pin Type I=Digital Input, O=Digital Output; AI=Analog Input; P=Power Pin; AP=Analog Power

4 BLOCK DIAGRAM

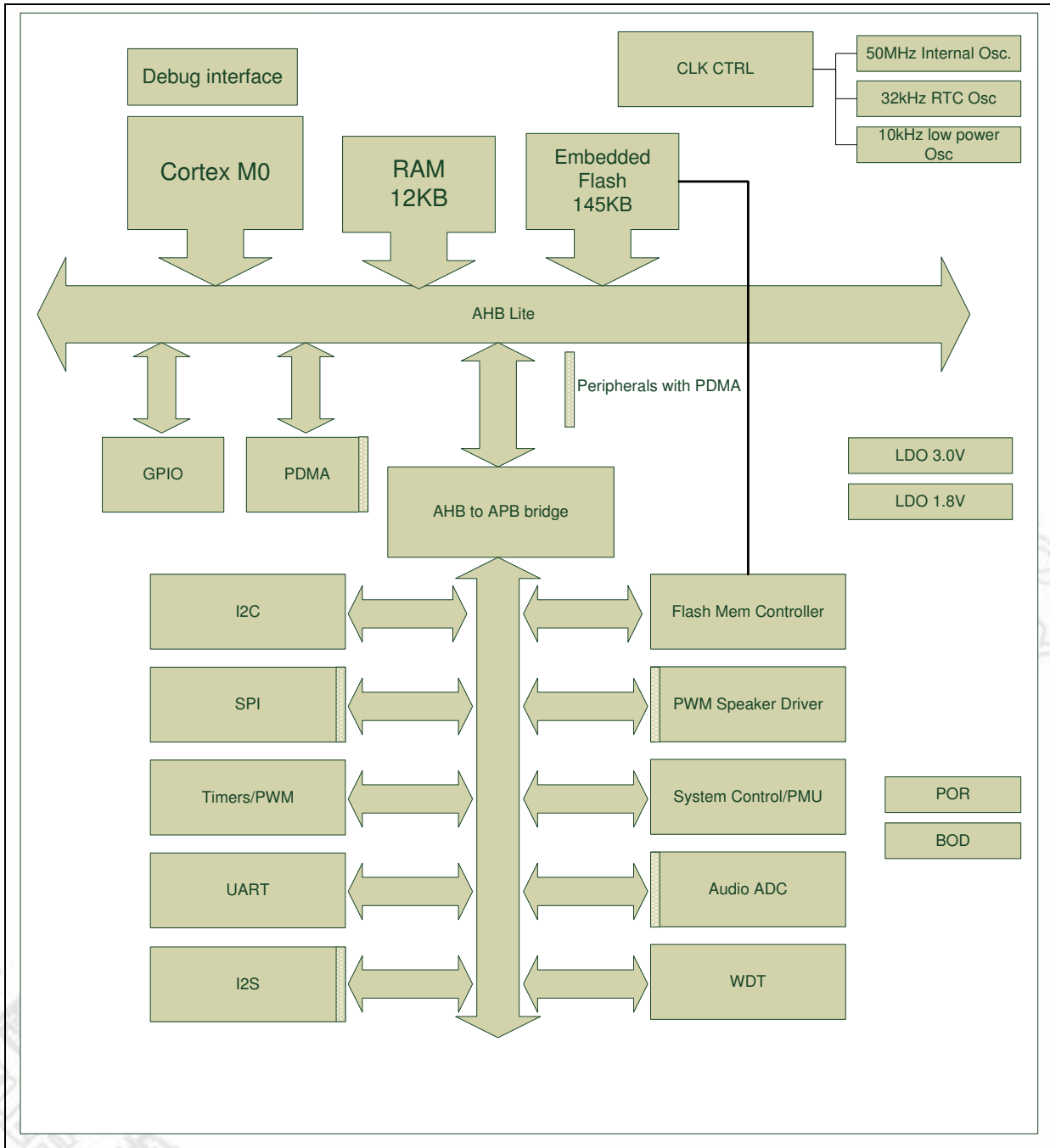
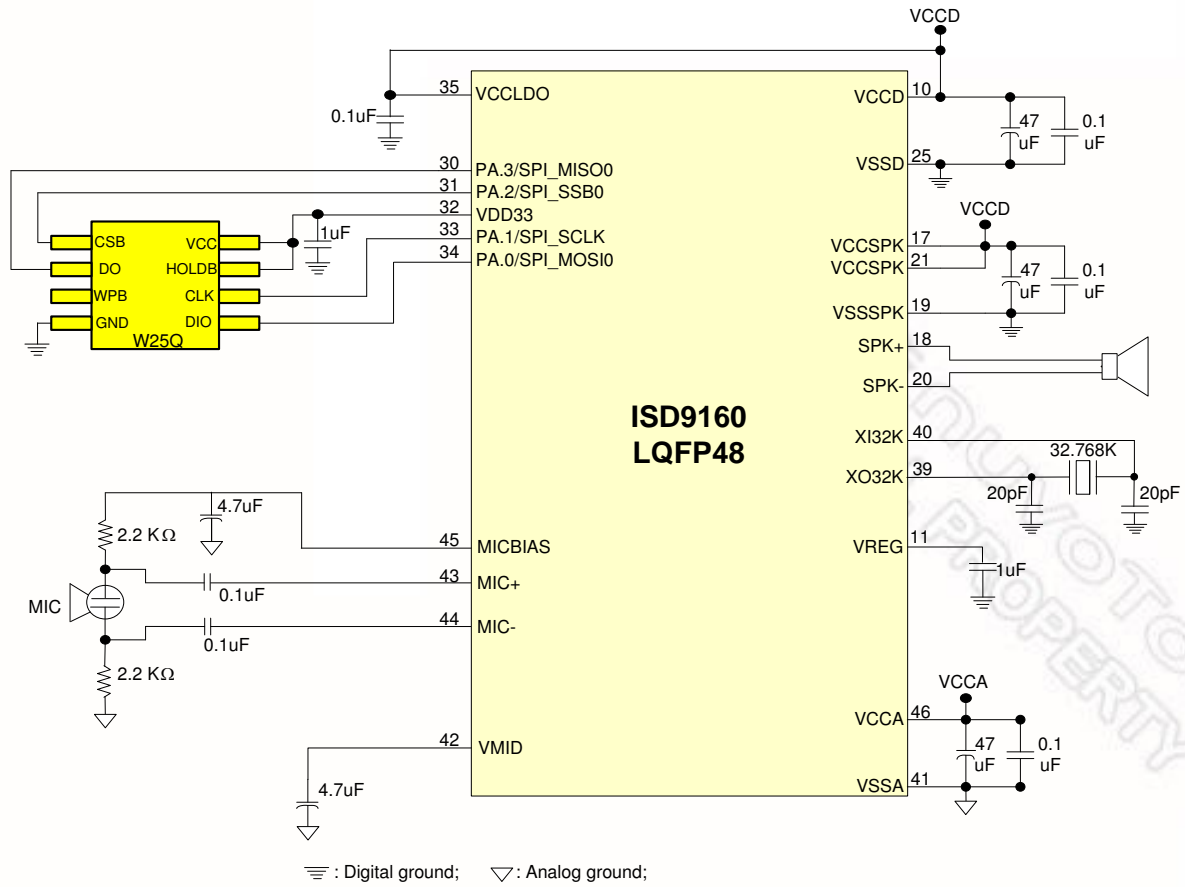

Figure 4-1 ISD9100 Block Diagram

新加坡 NUVOTON  
INTELLECTUAL PROPERTY

5 APPLICATION DIAGRAM



新唐科技 NUVOTON  
INTELLECTUAL PROPERTY



## 6 ELECTRICAL CHARACTERISTICS

### 6.1 Absolute Maximum Ratings

SYMBOL	PARAMETER	MIN	MAX	UNIT
DC Power Supply	VDD-VSS	-0.3	+6.0	V
Input Voltage	VIN	VSS-0.3	VDD+0.3	V
Oscillator Frequency	1/t <sub>CLCL</sub>	0	40	MHz
Operating Temperature	TA	-40	+85	°C
Storage Temperature	TST	-55	+150	°C
Maximum Current into V <sub>DD</sub>		-	120	mA
Maximum Current out of V <sub>SS</sub>			120	mA
Maximum Current sunk by a I/O pin			35	mA
Maximum Current sourced by a I/O pin			35	mA
Maximum Current sunk by total I/O pins			100	mA
Maximum Current sourced by total I/O pins			100	mA

**Note:** Exposure to conditions beyond those listed under absolute maximum ratings may adversely affects the lift and reliability of the device.

6.2 DC Electrical Characteristics

(VDD-VSS=3.3V, TA = 25°C, FOSC = 49.152 MHz unless otherwise specified.)

PARAMETER	SYM.	SPECIFICATION				TEST CONDITIONS
		MIN.	TYP.	MAX.	UNIT	
Operation voltage	V <sub>DD</sub>	2.4		5.5	V	V <sub>DD</sub> =2.4V ~ 5.5V up to 49 MHz
Power Ground	V <sub>SS</sub> AV <sub>SS</sub>	-0.3			V	
Analog Operating Voltage	AV <sub>DD</sub>	0		V <sub>DD</sub>	V	
Analog Reference Voltage	Vref	0		AV <sub>DD</sub>	V	
Operating Current Normal Run Mode @ 49.152 MHz	I <sub>DD1</sub>		24.8		mA	V <sub>DD</sub> = 5.5V, Enable all IP.
	I <sub>DD2</sub>		19.7		mA	V <sub>DD</sub> =5.5V, disable all IP
	I <sub>DD3</sub>		23.6		mA	V <sub>DD</sub> = 3V, enable all IP
	I <sub>DD4</sub>		18.3		mA	V <sub>DD</sub> = 3V, disable all IP
Operating Current Normal Run Mode @ 32.768Mhz	I <sub>DD5</sub>		18.8		mA	V <sub>DD</sub> = 5.5V, Enable all IP.
	I <sub>DD6</sub>		15.0		mA	V <sub>DD</sub> = 5.5V, Disable all IP.
	I <sub>DD7</sub>		17.6		mA	V <sub>DD</sub> = 3V, Enable all IP.
	I <sub>DD8</sub>		13.8		mA	V <sub>DD</sub> = 3V, Disable all IP.

Operating Current Normal Run Mode @ 12.288MHz	I <sub>DD9</sub>	12.5	mA	V <sub>DD</sub> = 5.5V enable all IP
	I <sub>DD10</sub>	10.3	mA	V <sub>DD</sub> = 5.5V, disable all IP
	I <sub>DD11</sub>	11.4	mA	V <sub>DD</sub> = 3V enable all IP
	I <sub>DD12</sub>	9	mA	V <sub>DD</sub> = 3V, disable all
Operating Current Normal Run Mode @ 4.9152MHz	I <sub>DD13</sub>	9.7	mA	V <sub>DD</sub> = 5.5V, Enable all IP.
	I <sub>DD14</sub>	8.1	mA	V <sub>DD</sub> = 5.5V, Disable all IP.
	I <sub>DD15</sub>	8.7	mA	V <sub>DD</sub> = 3V, Enable all IP.
	I <sub>DD16</sub>	7.0	mA	V <sub>DD</sub> = 3V, Disable all IP.
Operating Current Sleep Mode	I <sub>IDLE1</sub>	10	mA	V <sub>DD</sub> = 5.5V
	I <sub>IDLE1</sub>	9	mA	V <sub>DD</sub> = 3.3V
Operating Current Deep Sleep Mode	I <sub>IDLE1</sub>	10	mA	V <sub>DD</sub> =5.5V
	I <sub>IDLE1</sub>	8	mA	V <sub>DD</sub> = 3.3V
Standby Power down mode(SPD)	I <sub>IDLE1</sub>	3	uA	V <sub>DD</sub> =3.3V 32K running with RTC
	I <sub>IDLE1</sub>	1	uA	V <sub>DD</sub> = 3.3V 16K running
Operating Current Deep Power down mode(DPD)	I <sub>IDLE1</sub>	500	nA	V <sub>DD</sub> =3.3V Wakeup with16K
	I <sub>IDLE1</sub>		nA	V <sub>DD</sub> = 3.3V wakeup with wakeup pin

Input Current PA, PB (Quasi-bidirectional mode)	$I_{IN1}$	-60	-	+15	$\mu A$	$V_{DD} = 5.5V, V_{IN} = 0V$ or $V_{IN} = V_{DD}$
Input Current at /RESET <sup>[1]</sup>	$I_{IN2}$	-55	-45	-30	$\mu A$	$V_{DD} = 3.3V, V_{IN} = 0.45V$
Input Leakage Current PA, PB	$I_{LK}$	-2	-	+2	$\mu A$	$V_{DD} = 5.5V, 0 < V_{IN} < V_{DD}$
Logic 1 to 0 Transition Current PA~PB (Quasi-bidirectional mode)	$I_{TL}^{[3]}$	-650	-	-200	$\mu A$	$V_{DD} = 5.5V, V_{IN} < 2.0V$
Input Low Voltage PA, PB (TTL input)	$V_{IL1}$	-0.3	-	0.8	V	$V_{DD} = 4.5V$
		-0.3	-	0.6		$V_{DD} = 2.5V$
Input High Voltage PA, PB (TTL input)	$V_{IH1}$	2.0	-	$V_{DD} + 0.2$	V	$V_{DD} = 5.5V$
		1.5	-	$V_{DD} + 0.2$		$V_{DD} = 3.0V$
Input Low Voltage XT1 <sup>[*2]</sup>	$V_{IL3}$	0	-	0.8	V	$V_{DD} = 4.5V$
		0	-	0.4		$V_{DD} = 3.0V$
Input High Voltage XT1 <sup>[*2]</sup>	$V_{IH3}$	3.5	-	$V_{DD} + 0.2$	V	$V_{DD} = 5.5V$
		2.4	-	$V_{DD} + 0.2$		$V_{DD} = 3.0V$
Input Low Voltage X321 <sup>[*2]</sup>	$V_{IL4}$	0	-	0.4	V	
Input High Voltage X321 <sup>[*2]</sup>	$V_{IH4}$	1.7		2.5	V	
Negative going threshold (Schmitt input), /REST	$V_{ILS}$	-0.5	-	$0.3V_{DD}$	V	
Positive going threshold (Schmitt input), /REST	$V_{IHS}$	$0.7V_{DD}$	-	$V_{DD} + 0.5$	V	
Hysteresis voltage of PA~PB(Schmitt input)	$V_{HY}$		$0.2V_{DD}$		V	

新唐科技 NUVOTON  
INTELLECTUAL PROPERTY

Source Current PA, PB Quasi-bidirectional Mode)	I <sub>SR11</sub>	-300	-370	-450	μA	V <sub>DD</sub> = 4.5V, V <sub>S</sub> = 2.4V
	I <sub>SR12</sub>	-50	-70	-90	μA	V <sub>DD</sub> = 2.7V, V <sub>S</sub> = 2.2V
	I <sub>SR12</sub>	-40	-60	-80	μA	V <sub>DD</sub> = 2.5V, V <sub>S</sub> = 2.0V
Source Current PA, PB (Push-pull Mode)	I <sub>SR21</sub>	-20	-24	-28	mA	V <sub>DD</sub> = 4.5V, V <sub>S</sub> = 2.4V
	I <sub>SR22</sub>	-4	-6	-8	mA	V <sub>DD</sub> = 2.7V, V <sub>S</sub> = 2.2V
	I <sub>SR22</sub>	-3	-5	-7	mA	V <sub>DD</sub> = 2.5V, V <sub>S</sub> = 2.0V
Sink Current PA, PB (Quasi-bidirectional and Push-pull Mode)	I <sub>SK1</sub>	10	16	20	mA	V <sub>DD</sub> = 4.5V, V <sub>S</sub> = 0.45V
	I <sub>SK1</sub>	7	10	13	mA	V <sub>DD</sub> = 2.7V, V <sub>S</sub> = 0.45V
	I <sub>SK1</sub>	6	9	12	mA	V <sub>DD</sub> = 2.5V, V <sub>S</sub> = 0.45V
Brownout voltage with BOV_VL [2:0] =000b	V <sub>BO2.1</sub>		2.15		V	
Brownout voltage with BOV_VL [2:0] =001b	V <sub>BO2.2</sub>		2.25		V	
Brownout voltage with BOV_VL [2:0] =010b	V <sub>BO2.4</sub>		2.45		V	
Brownout voltage with BOV_VL [2:0] =011b	V <sub>BO2.5</sub>		2.55		V	
Brownout voltage with BOV_VL [2:0] =100b	V <sub>BO2.7</sub>		2.7		V	
Brownout voltage with BOV_VL [2:0] =101b	V <sub>BO2.8</sub>		2.8		V	
Brownout voltage with BOV_VL [2:0] =110b	V <sub>BO3.0</sub>		3.0		V	
Brownout voltage with BOV_VL [2:0] =111b	V <sub>BO4.5</sub>		4.55		V	

**Notes:**

1. /REST pin is a Schmitt trigger input.
2. Crystal Input is a CMOS input.
3. Pins of P0, P1, P2, P3 and P4 can source a transition current when they are being externally driven from 1 to 0. In the condition of V<sub>DD</sub>=5.5V, the transition current reaches its maximum value when V<sub>in</sub> approximates to 2V.



### 6.3 AC Electrical Characteristics

#### 6.3.1 External 32kHz XTAL Oscillator

PARAMETER	CONDITION	MIN.	TYP.	MAX.	UNIT
Input clock frequency	External crystal	-	32.768	-	kHz
Temperature	-	-40	-	85	°C
V <sub>DD</sub>	-	2.4	-	5.5	V

#### 6.3.2 Internal 49.152MHz Oscillator

PARAMETER	CONDITION	MIN.	TYP.	MAX.	UNIT
Supply voltage <sup>[1]</sup>	-	2.4	-	5.5	V
Center Frequency	-	-	49.152	-	MHz
Calibrated Internal Oscillator Frequency	+25°C; V <sub>DD</sub> =5V	-1	-	1	%
	-40°C~+85°C; V <sub>DD</sub> =2.5V~5.5V	-4	-	4	%

#### 6.3.3 Internal 16 kHz Oscillator

PARAMETER	CONDITION	MIN.	TYP.	MAX.	UNIT
Supply voltage	-	2.4	-	5.5	V
Center Frequency	-	-	10	-	kHz
Calibrated Internal Oscillator Frequency	+25°C; V <sub>DD</sub> =5V	-10	-	10	%
	-40°C~+85°C; V <sub>DD</sub> =2.5V~5.5V	-20	-	20	%

**Notes:**

\*1. Internal operation voltage comes from LDO.

#### 6.3.4 Reset Characteristics

(V<sub>DD</sub>-V<sub>SS</sub>=5V, T<sub>A</sub> = 25°C, F<sub>OSC</sub> = 49.152 MHz unless otherwise specified.)

Parameter No.	Parameter	Parameter Name	Min	Typ	Max	Unit
R1	V <sub>TH</sub>	Reset threshold	1	1.7	2	V
R2	T <sub>VDDRISE</sub>	Supply voltage (V <sub>DD</sub> ) rise time (0V-5V), power on reset	-	-	100	ms
R3	T <sub>POR</sub>	Power-On Reset timeout	-	-	12	µs
R4	T <sub>IRPOR</sub>	Internal reset timeout after POR	-	-	45	µs
R5	T <sub>MIN</sub>	Minimum RESETN pulse width	100	-	-	ns
R6	T <sub>IRHWR</sub>	Internal reset timeout after hardware reset (RESETN pin)	-	-	20	µs

R7	TIRSWR	Internal reset timeout after software-initiated system reset	-	-	2	
R8	TIRWDR	Internal reset timeout after watchdog reset	-	-	3 * <sup>2</sup>	μs

**\*Notes:**

2. It will be 6500us when use OSC\_10K as the WDG clock.

6.3.4.1 Power-On Reset Timing

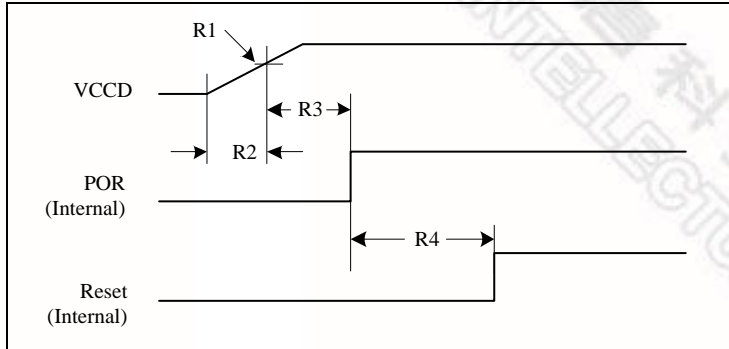

6.3.4.2 External Reset Timing (RESETN)

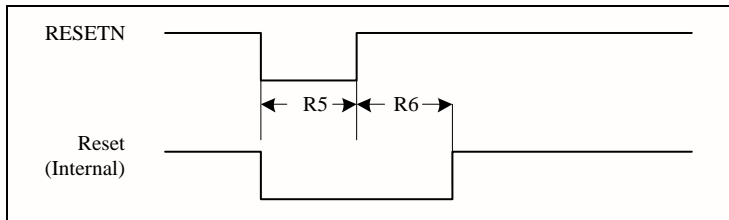

6.3.4.3 Software Reset Timing

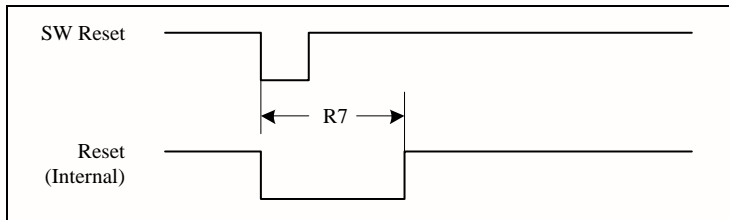

6.3.4.4 Watchdog Reset Timing

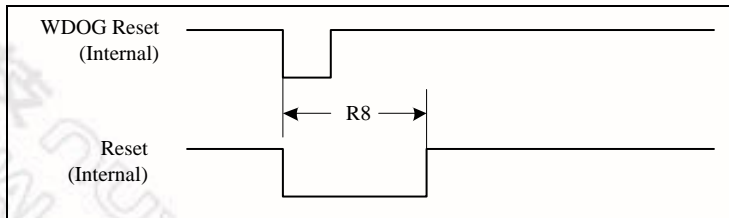

7 PACKAGE DIMENSIONS

7.1.1 48L LQFP (7x7x1.4mm footprint 2.0mm)

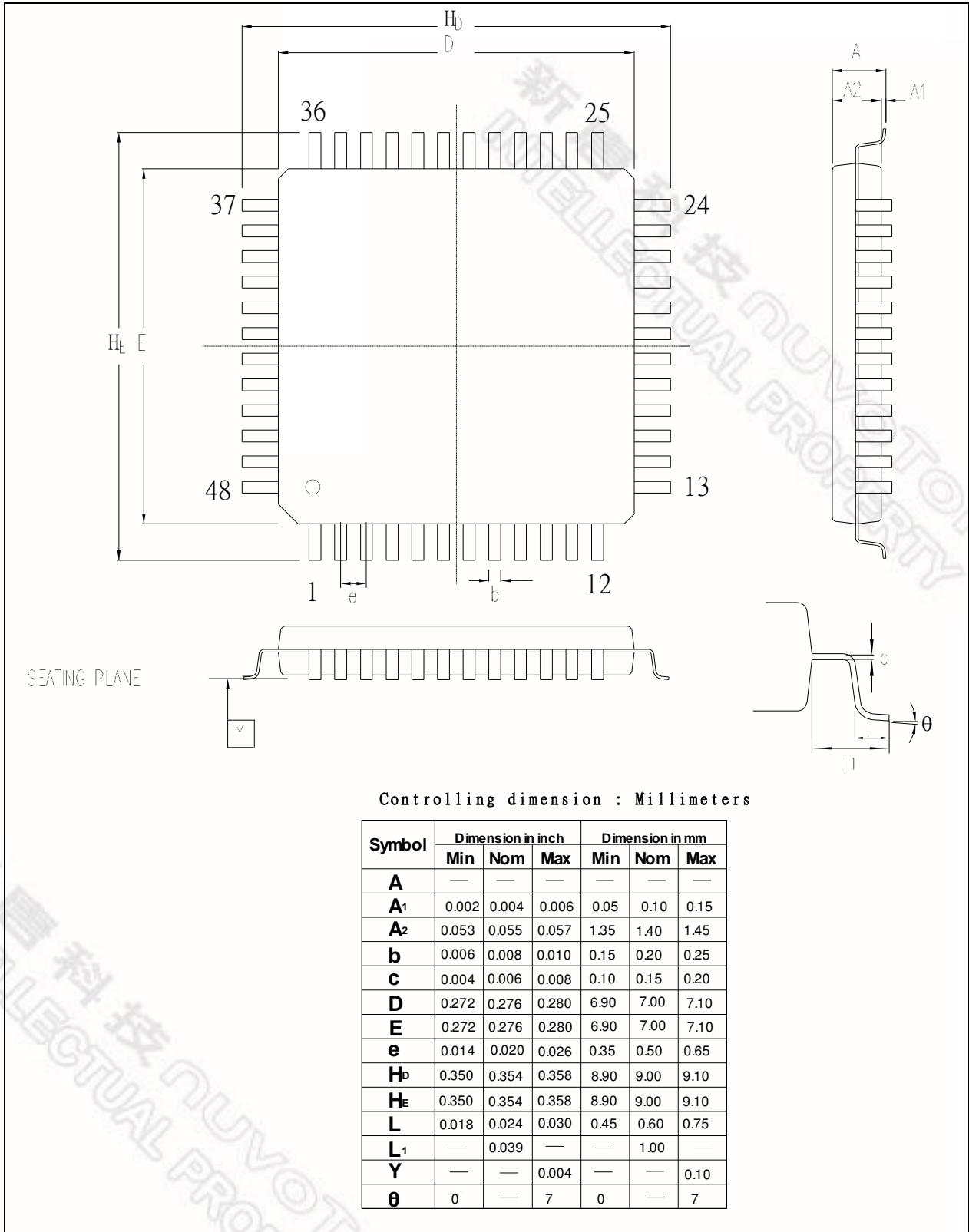

8 ORDERING INFORMATION

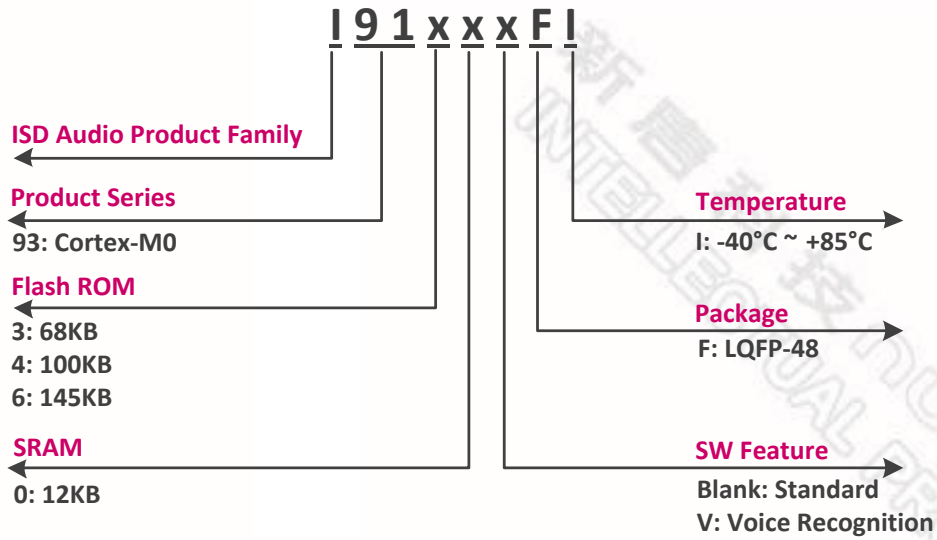

新唐科技 NUVOTON  
INTELLECTUAL PROPERTY

**9 REVISION HISTORY**

VERSION	DATE	PAGE/ CHAP.	DESCRIPTION
V0.1	May 25, 2011	-	First Release.
V1.01	Sep 6, 2011	-	<ul style="list-style-type: none"> <li>• Add better description of EINT0/1 and PB0/1 interrupts.</li> <li>• Unify the naming of capacitive touch sensing.</li> </ul>
V1.10	Sep 30, 2011	-	<ul style="list-style-type: none"> <li>• Revise the level value of Brown-out detector in Feature.</li> <li>• Correct the maximum voltage of DC Power Supply in section 6.1 Absolute Maximum Ratings</li> </ul>
V1.22	Nov 17, 2011	-	<ul style="list-style-type: none"> <li>• Update DC spec.</li> <li>• Add ordering information.</li> </ul>
V1.23	Sep 10, 2012		<ul style="list-style-type: none"> <li>• Remove "Preliminary"</li> <li>• Change internal oscillation 10K to 16K</li> <li>• Change minimum voltage (to 2.4V) in chapter 9 Electrical Characteristics</li> </ul>
V1.24	July 17, 2013		<ul style="list-style-type: none"> <li>• Change SNR to 92dB</li> <li>• Add RESET low specification in DC characteristic.</li> </ul>
V1.25	July 31, 2013		<ul style="list-style-type: none"> <li>• Update RESET timing spec.</li> </ul>
V1.30	Oct 24, 2014		<ul style="list-style-type: none"> <li>• Add ISD9130 and ISD9140 into the ISD9100 series.</li> </ul>

新唐科技 NUVOTON  
INTELLECTUAL PROPERTY



### Important Notice

Nuvoton products are not designed, intended, authorized or warranted for use as components in systems or equipment intended for surgical implantation, atomic energy control instruments, airplane or spaceship instruments, transportation instruments, traffic signal instruments, combustion control instruments, or for other applications intended to support or sustain life. Furthermore, Nuvoton products are not intended for applications wherein failure of Nuvoton products could result or lead to a situation where personal injury, death or severe property or environmental damage could occur.

Nuvoton customers using or selling these products for use in such applications do so at their own risk and agree to fully indemnify Nuvoton for any damages resulting from such improper use or sales.

---

Please note that all data and specifications are subject to change without notice. All the trademarks of products and companies mentioned in this datasheet belong to their respective owners.